



RAA31



RAA31.16



RAA31.26

Room Thermostats

RAA31..

Adjustable room thermostat for heating only **or** cooling only systems

- Room thermostat with manual ON/OFF switch
- Two-position control
- Switching voltage AC 24...250 V

Use

The RAA31.. room thermostat is used in heating only or cooling only systems to maintain the selected room temperature.

Typical use:

- Residential buildings
- Light industrial buildings

In conjunction with

- zone valves, thermal valves
- gas or oil burners
- fans
- pumps

Functions

The front of the unit carries an ON/OFF switch.

OFF

In the OFF position, the input voltage is physically separated from the output voltage.

ON

The RAA31.. room thermostat has separate outputs for heating only and cooling only. If the room temperature falls below the selected setpoint, the heating contact will close. If the room temperature exceeds the selected setpoint, the cooling contact will close.

Function diagrams

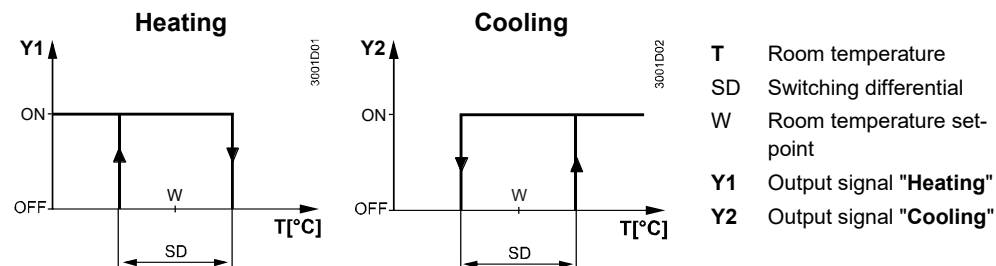

Type summary

Functionality	Order number (ASN)
Thermostat for heating or cooling application with ON/OFF switch Operating voltage AC 24...250 V	RAA31
Thermostat for heating or cooling application with ON/OFF switch and operation mode indication (LED) Operating voltage AC 230 V + /-10 %.	RAA31.16
Thermostat for heating or cooling application with ON/OFF switch and operation mode indication (LED) and independent ON/OFF switch Operating voltage AC 230 V +/-10 %.	RAA31.26

Equipment combinations

Type of unit	Type reference	Data sheet ¹⁾
Motoric on/off actuator	SFA21...	4863
Electric actuator (for small valves)	SFP21...	4865
Thermal actuator (for radiator valve)	STA21...	4877
Thermal actuator (for small valve 2.5 mm)	STP21...	4878

¹⁾ The documents can be downloaded from <http://siemens.com/bt/download>.

Accessories

Description	Type reference
Adapter plate 120 x 120 mm for 4" x 4" conduit boxes	ARG70
Adapter plate 96 x 120 mm for 2" x 4" conduit boxes	ARG70.1
Adapter plate for surface wiring 112 x 130 mm	ARG70.2

Technical design

Key features of the RAA31.. room thermostat:

- Two-position control
- Manual ON/OFF switch
- Gas-filled diaphragm

Adjustments

The required temperature is selected by a setpoint adjuster on the front of the thermostat.

The setpoint setting range can be mechanically limited by means of setpoint limiter under the cover.

Notes

Mounting, installation and commissioning

The room thermostat should be located where the air temperature can be sensed as accurately as possible, without getting adversely affected by direct solar radiation or other heat or refrigeration sources.

Mounting height is about 1.5 m above the floor.

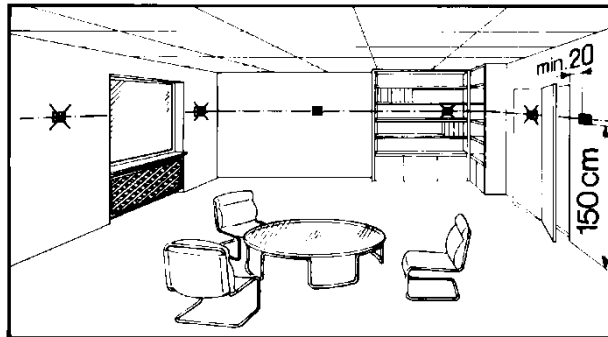

The unit can be fitted to most commercially available recessed conduit boxes or directly on the wall.

Only authorised personnel may open the unit to perform service.

The unit must be isolated from the mains supply before opening.

When installing the unit, fix the base plate first then hook on the thermostat body and make the electrical connections. Then fit the cover and secure it (also refer to separate mounting instructions).

The thermostat must be mounted on a flat wall.

The local electrical regulations must be complied with.

If there are thermostatic radiator valves in the reference room, set them to their fully open position.



Warning:
AC 24...250 V!



Warning!

No internal line protection for supply lines to external consumers (Y1, Y2)

Risk of fire and injury due to short-circuits!

- Adapt the line diameters as per local regulations to the rated value of the installed overcurrent protection device.

Maintenance

The room thermostat is maintenance-free.

Mechanical design

The diaphragm is filled with environmentally friendly gas.

The thermostat housing is made of plastic.

Ordering

Type (ASN)	Part number (SSN)	Description
RAA31	S55770-T221	Room thermostat RAA31
RAA31.16	S55770-T222	Room thermostat RAA31.16
RAA31.26	S55770-T223	Room thermostat RAA31.26

Disposal



The devices are considered electronics devices for disposal in term of European Directive 2012/19/EU and may not be disposed of as domestic waste.

- Dispose of the device via the channels provided for this purpose
- Comply with all local and currently applicable laws and regulations.

Technical Data

Power



Switching capacity	
Voltage	AC 24...250 V / 50 or 60 Hz
• RAA31...	AC 230 V +/-10 %
• RAA31.16 and 31.26	0.5 VA (Only RAA31.16 and RAA31.26)
Power consumption of each LED	0.2...6 (2.5) A
Current	50 or 60 Hz
Frequency	



No internal fuse

External preliminary protection with max. C 10 A circuit breaker in the supply line required under all circumstances

Operational data

Screw terminals for	2 x 1.5 mm ² (min. 0.5 mm ²)
---------------------	---

Switching differential SD	≤1 K
---------------------------	------

Setpoint setting range	8...30 °C
------------------------	-----------

Environmental conditions

Operation	to IEC 60721-3-3
-----------	------------------

Climatic conditions	Class 3K5
---------------------	-----------

Temperature	0...50 °C
-------------	-----------

Humidity	<95 % r.h.
----------	------------

Pollution degree	Normal, to EN 60730-1
------------------	-----------------------

Transport / storage	to IEC 60721-3-2
---------------------	------------------

Climatic conditions	Class 2K3/1K3
---------------------	---------------

Temperature	-20...50 °C
-------------	-------------

Humidity	<95 % r.h.
----------	------------

Mechanical conditions	Class 2M2
-----------------------	-----------

Industry standards

EU conformity (CE)	8000064801 ¹⁾
--------------------	--------------------------

UK conformity (UKCA)	A5W00209372A ¹⁾
----------------------	----------------------------

RCM conformity	CE1T3561en_C1 ¹⁾
----------------	-----------------------------

Safety standard	II to EN 60730-1
-----------------	------------------

Degree of protection of housing	IP30 to EN 60529
---------------------------------	------------------

Environmental compatibility

The product environmental declarations CE1E3015, CE1E3561¹⁾ contain data on environmentally compatible product design and assessments (RoHS compliance, materials composition, packaging, environmental benefit, disposal).

Mechanical design

Weight	0.14 kg
--------	---------

Colour of top cover	White, NCS 50502-G (RAL 9003)
---------------------	-------------------------------

¹⁾ The documents can be downloaded from <http://siemens.com/bt/download>.

Connection diagrams

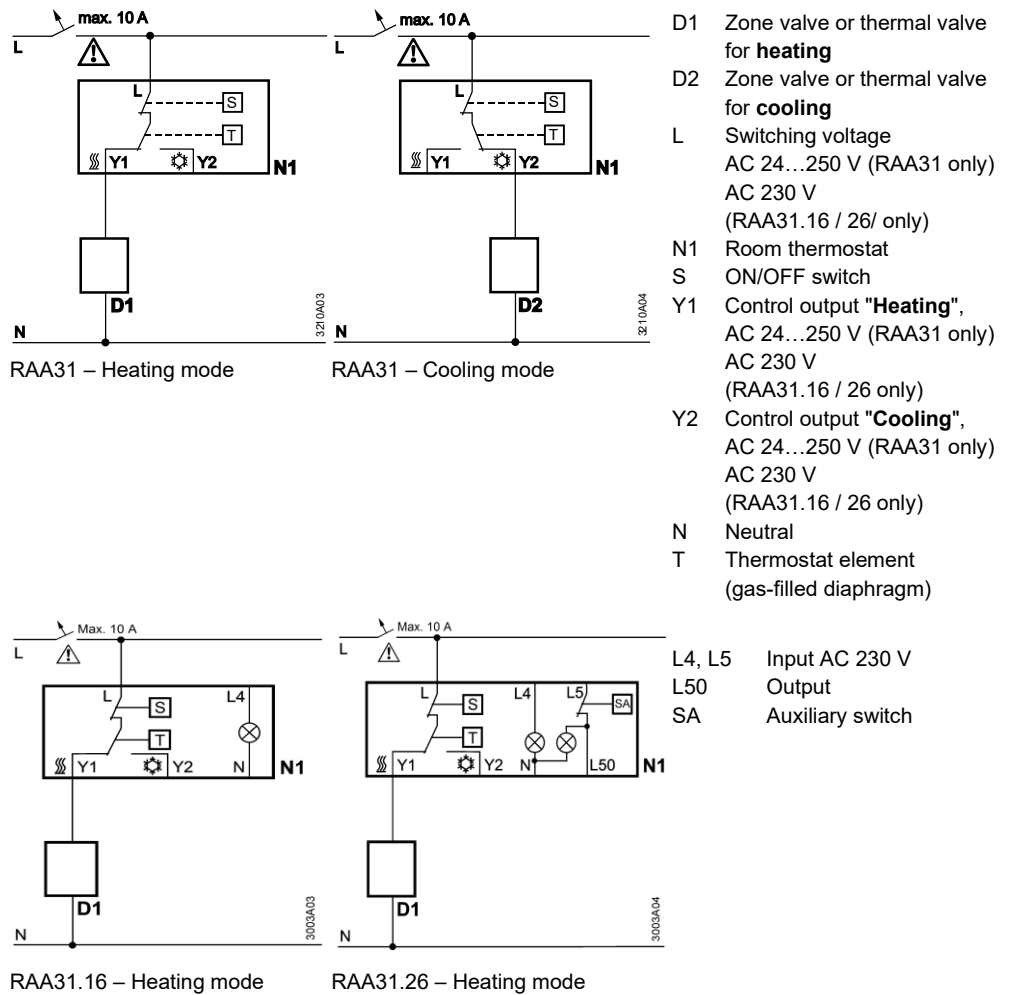

Dimensions

RAA31 and RAA31.16

Room thermostat

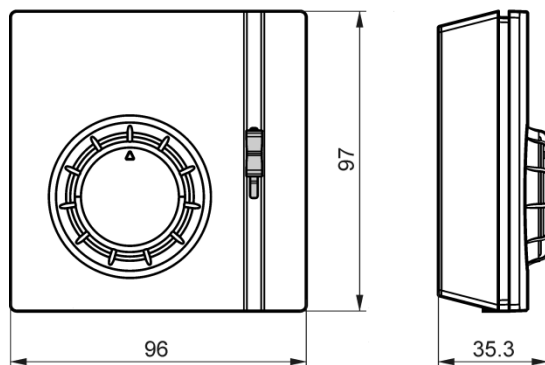

Base plate

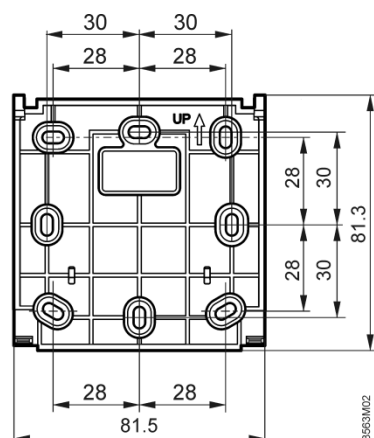

RAA31.26

Room thermostat

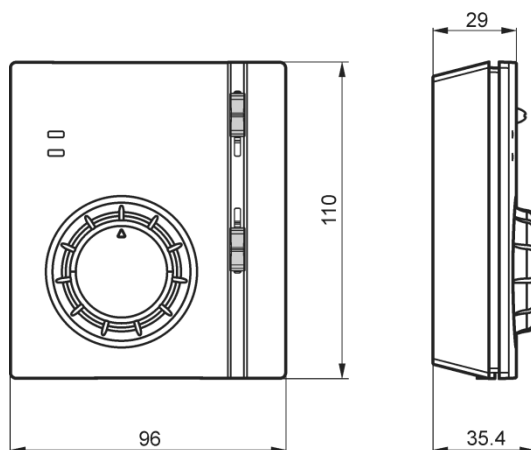

Base plate

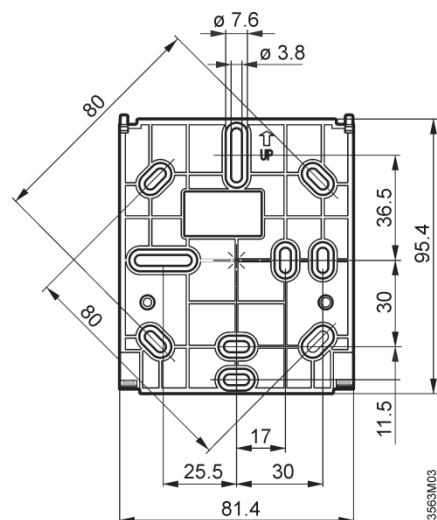

Remarks

Heating:

Because of the unavoidable self heating effects of the electrical current, any loads of more than 3 Amperes connected to the unit can influence the control behavior and temperature accuracy in a negative way.

Cooling:

Because of the unavoidable self heating effects of the electrical current, any loads of more than 1 Amperes connected to the unit can influence the control behavior and temperature accuracy in a negative way.