

Wireless programmable room thermostat

RDE50.1RF/SET



Wireless programmable room thermostat

- Two-position control with On/Off relay output receiver for heating
- Operating modes: Comfort and Economy mode
- 7 day time program and manual operation
- Holiday mode
- Keypad lock
- Periodic pump run and anti-lime function
- Battery-powered (2 AAA Alkaline batteries)
- 433 MHz radio transmission frequency
- Including wall-mount RADIO RECEIVER
- Including fold-out stand

Use

The wireless thermostat is used for the control of the room temperature in heating systems. For the control of the following pieces of equipment:

- Wall hung boilers
- Thermic valves or zone valves
- Gas or oil burners
- Fans
- Pumps

Functions

The wireless thermostat acquires the room temperature with its integrated sensor and maintains the setpoint by delivering control commands. The switching differential is 0.5 K.

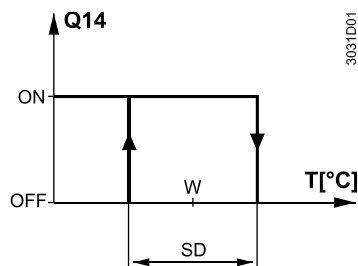

T: Room temperature

SD: Switching differential

W: Room temperature setpoint

Q14: Output signal for heating from receiver

Type summary

Product no.	Stock no.	Operating voltage	Description
RDE50.1RF/SET	S55770-T499	DC 3 V (2 x 1.5 V AAA Alkaline batteries)	Wireless room thermostat for heating applications with 7-Day time program

Ordering

When ordering, specify both product number / stock number and name: e.g.
RDE50.1RF/SET / S55770-T499 Wireless programmable room thermostat

Product documentation

Title	Document ID
Mounting instructions	A6V13156963
Operating instructions	A6V13156975
CE declaration	A5W00248943A
UKCA	A5W00248944A
Environmental product declaration	A5W00244893A

Related documents such as environmental declarations, CE declarations, etc., can also be downloaded at the following Internet address:

www.siemens.com/bt/download

Safety

⚠ CAUTION**National safety regulations**

Failure to comply with national safety regulations may result in personal injury and property damage.

- Observe national provisions and comply with the appropriate safety regulations.

⚠ WARNING**Explosion due to fire or short-circuit, even with discharged batteries**

Risk of injury due to flying parts

- Prevent the batteries from coming into contact with water.
- Do not recharge batteries.
- Do not damage or disassemble batteries.
- Do not heat batteries over 85 °C.

⚠ WARNING**Risk of explosion**

Personal injury and property damage

- Install the battery at the correct polarity (+/-) using the illustration in the battery compartment.
- Install only the correct battery types according to the indication in the battery compartment.
- In case of a leakage, avoid contact with skin, eyes and mucous membranes.
- Remove leaking battery from the battery compartment with a cloth.

Observe the following:

- The batteries must be new and undamaged.
- Do not mix new and used batteries.
- Store, transport and dispose of the batteries in compliance with local requirements, regulations and laws. Also observe the instructions of the battery manufacturer.

NOTICE**Radio frequency energy**

Interference to radio communications

- Install and use equipment in accordance with installation guide.
- Read all regulatory compliance information.

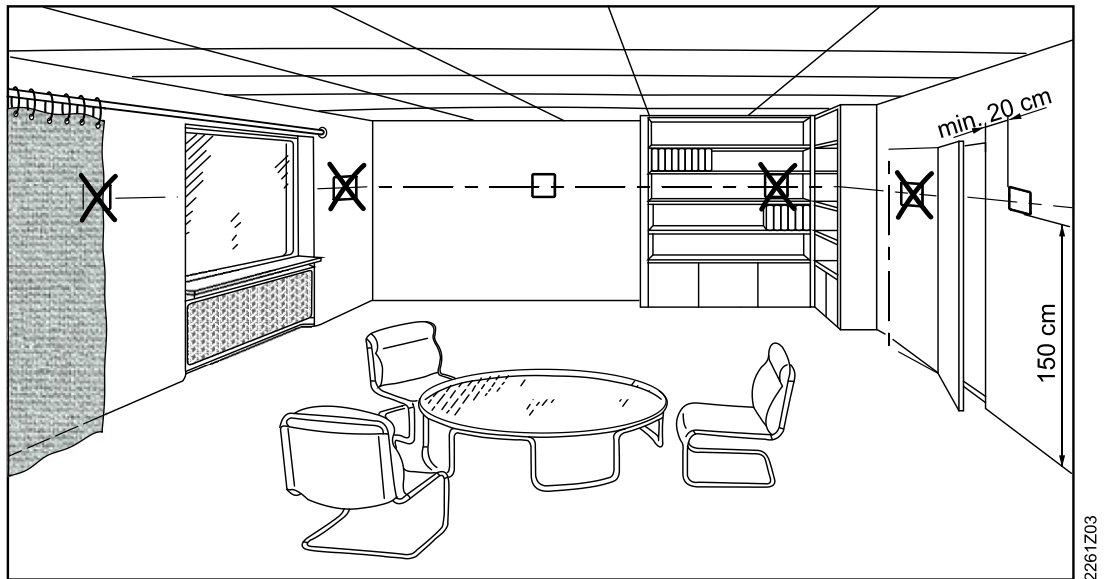

- Recommended height: 1.5 m above the floor.
- Do not mount the devices in recesses, shelves, behind curtains or doors, or above or near heat sources.
- Avoid direct solar radiation and drafts.
- Avoid unheated (uncooled) building area such as outside walls.
- The device can be fitted to a recessed conduit box or directly on the wall.
- Seal the conduit box or the installation tube if any, as air currents can affect sensor readings.
- Adhere to allowed ambient conditions.

The thermostat can also be used in a portable manner. It features a fold-out stand allowing it to be placed on a horizontal surface such as a bedside table.

When mounting the unit, install the baseplate first, then snap on the thermostat and fix with screwdriver.







The receiver is provided with a baseplate. Fix the baseplate first, make the electrical connections and fit and secure the receiver (see Mounting Instructions A6V13156963).

The thermostat must be mounted on a flat wall and in compliance with local regulations.

If there are thermostatic radiator valves in the reference room, they must be set to their fully open position.

Operating modes

The wireless thermostat provides Comfort mode and, optionally, Economy mode. The difference between Comfort and Economy mode is only the room temperature setpoint. The changeover between the operating modes can be made either automatically according to the 7-day time patterns or manually with the operating mode button.

Comfort mode	When Comfort mode is activated, symbol  appears on the display. The setpoint can be readjusted by pressing buttons "+" and "-".
Economy mode	When Economy mode is activated, symbol  appears on the display. The setpoint can be readjusted by pressing buttons "+" and "-".
7-day time program	The changeover between the operating modes can take place either automatically  or manually ( , ) depending on the activated operating mode. When the activated operating mode is in  , changeover takes place automatically according to the selected switching pattern. For every weekday, the thermostat has a predefined time program that can be adjusted by users:

Day(s)	Comfort mode	Economy mode
Mon (1) – Fri (5)	7:00 – 9:00 hr and 17:00 – 22:00 hr	22:00 – 7:00 hr and 09:00 – 17:00 hr
Sat (6) – Sun (7)	7:00 – 22:00 hr	22:00 – 7:00 hr

The current setpoint can be temporarily readjusted by pressing buttons "+" and "-". The setpoint then is reset to its initial value the next time automatic or manual changeover takes place.

When the operating mode is set to ☀️ or 🌙, the thermostat maintains Comfort mode or Economy mode respectively.

- Holiday mode** When holiday mode is activated, symbol 📅 appears on the display. The countdown days in holiday mode can be adjusted by pressing "+" and "-" from 0 to 365 days. The holiday mode setpoint can be adjusted.
- Keypad lock** Press and hold for operating mode button for 7 seconds and this activates the keypad lock 🔑.
- Periodic pump run and anti-lime function** Applicable with controlled circulating pump or valve. This function protects the pump or valve during extended OFF periods against possible seizure caused by liming. Periodic pump run is activated every 24 hours at 12 p.m. for three minutes (symbol 🔥 is displayed during active pump run). This function can be enabled and disabled by means of a parameter.

Maintenance

The thermostat is maintenance-free.

Change of batteries

Before the batteries are exhausted, the symbol for changing the batteries appears. In that case, there are 5 days left to change the batteries.

Disposal



The device is considered an electronic device for disposal in accordance with European Directive and may not be disposed of as domestic waste.

- Use only designated channels for disposing the devices.
- Comply with all local and currently applicable laws and regulations.
- Dispose of empty batteries at designated collection points.

Technical data

Thermostat /
Transmitter

Power supply	
Operating voltage	DC 3 V (2 x 1.5 V AAA Alkaline batteries)
Battery life	> 1 year (AAA Alkaline batteries)

Functional data	
Switching differential SD	0.5 K
Setpoint setting range	4...35 °C (Default:20 °C)
Comfort operation	4...35 °C (Default:16 °C)
Economy mode	4...35 °C (Default:16 °C)
Holiday mode	4...35 °C (Default:12 °C)
Increments	0.5 °C
Resolution of settings and displays	
Setpoint	0.5 °C
Switching times	15 min
Actual value displays	0.5 °C
Time of day displays	1 min

Ambient conditions and protection classification	
Safety class	III to EN60730-1
Pollution degree	2
Degree of protection of housing	IP30 to EN60529
Climatic ambient conditions	
- Storage as per IEC60721-3	
Climatic conditions	Class 2K3
Temperature	-25...+70 °C
Humidity	< 93 % r.h.
Mechanical conditions	Class 2M2
- Transport as per IEC60721-3	
Climatic conditions	Class 2K3
Temperature	-25...+70 °C
Humidity	< 93 % r.h.
Mechanical conditions	Class 2M2
- Operation as per IEC60721-3	
Climatic conditions	Class 3K3
Temperature	0...45 °C
Humidity	< 85 % r.h.

Radio receiver
433 MHz

Power supply	
Operating voltage	AC 230 V
Power	8 VA
Frequency	50 Hz

Outputs	
Switching capacity of relays Voltage Current	AC 24...230 V 5(2) A
External protection for incoming cable	Max. 10 A
Circuit breaker Circuit breaker tripping characteristic	Type B, C or D to EN60898 and EN60947

Ambient conditions and protection classification	
Safety class	II to EN60730
Pollution degree	2
Degree of protection of housing	IP30 to EN60529
Climatic ambient conditions - Storage as per IEC60721-3 Climatic conditions Temperature Humidity Mechanical conditions	Class 2K3 -25...+70 °C < 93 % r.h. Class 2M2
- Transport as per IEC60721-3 Climatic conditions Temperature Humidity Mechanical conditions	Class 2K3 -25...+70 °C < 93 % r.h. Class 2M2
- Operation as per IEC60721-3 Climatic conditions Temperature Humidity	Class 3K3 0...45 °C < 85 % r.h.

Standards, directives and approvals	
EU conformity (CE)	A5W00248943A *)
UKCA	A5W00248944A *)
Eco design and labeling directives	Based on EU Regulation 813/2013 (Eco design directive) and 811/2013 (Labeling directive) concerning space heaters, combination heaters, the following class apply: Application with On/Off operation of a heater Class I Value 1%
Environmental compatibility	The product environmental declaration (A5W00244893A *) contains data on environmentally compatible product design and assessments (RoHS compliance, materials composition, packaging, environmental benefit, disposal).

General	
Electrical connections Connection terminals For solid wires For stranded wires	Screw terminals 2 x 1.5 mm ² 1 x 2.5 mm ²
Weight without/with package	312.5 g / 433.1 g

*) The documents can be downloaded from <http://siemens.com/bt/download>.

Connection diagrams

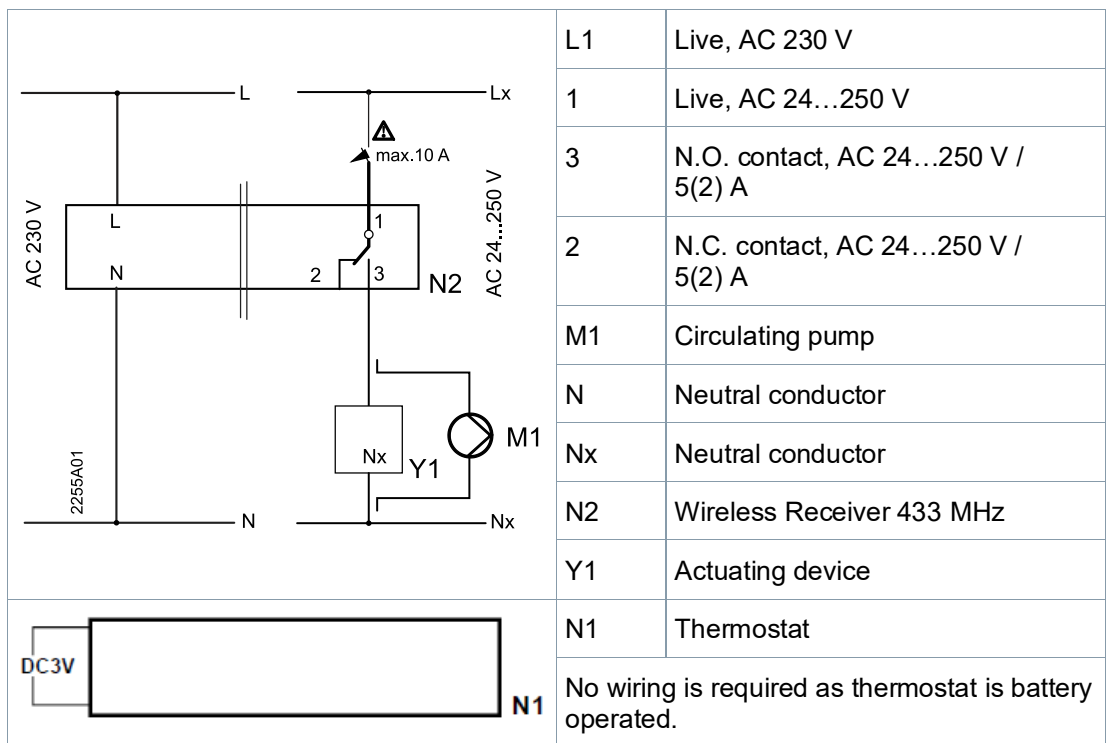

<p>Wireless room thermostat with receiver control of a gas-fired wall-hung boiler</p>		<p>Wireless room thermostat with receiver control of atmospheric gas burner</p>	
<p>Wireless room thermostat with receiver control of a heating circuit pump (pre-control by manual mixing valve)</p>			
F1	Thermal reset limit thermostat	N1	Room thermostat RDE50.1RF/SET (Transmitter)
F2	Safety limit thermostat	N2	RCR50RF (Receiver)
M1	Circulating pump	Y1	3-port valve with manual adjustment
Y2	Magnetic valve		

Dimensions

Thermostat

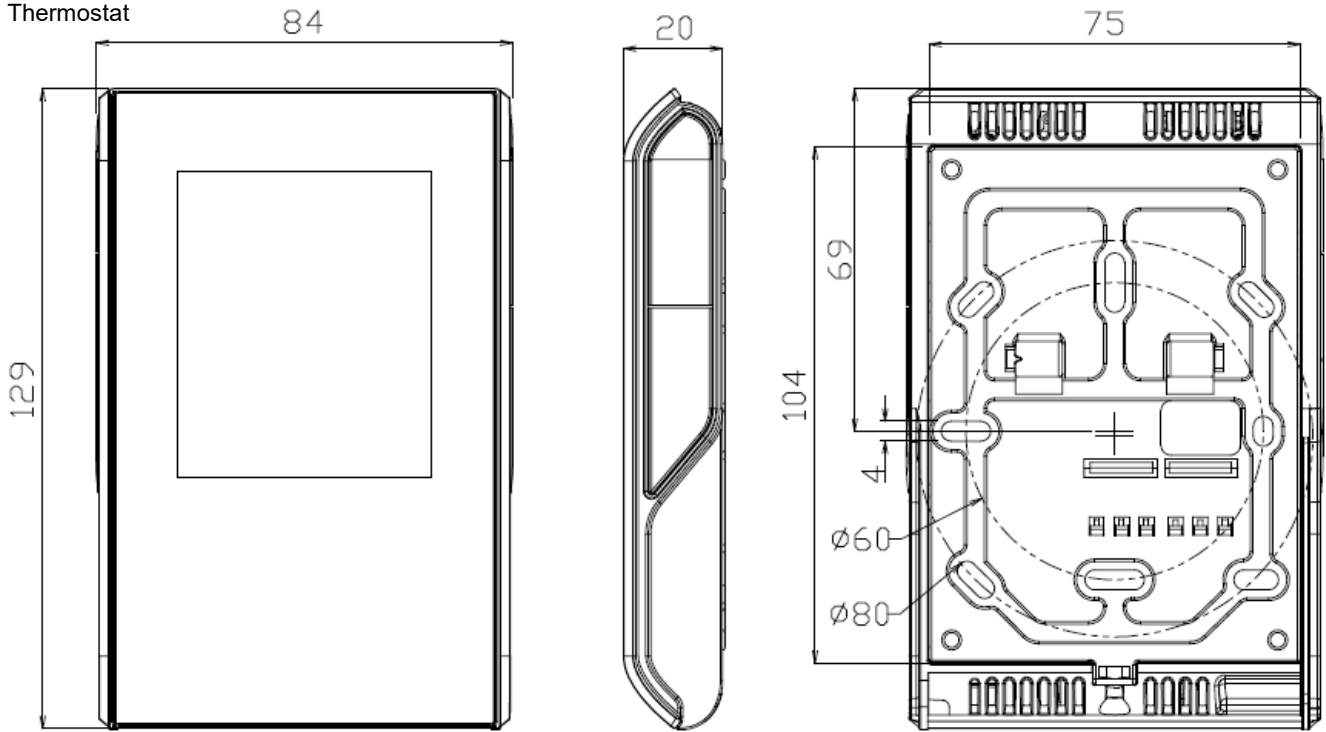

Radio receiver

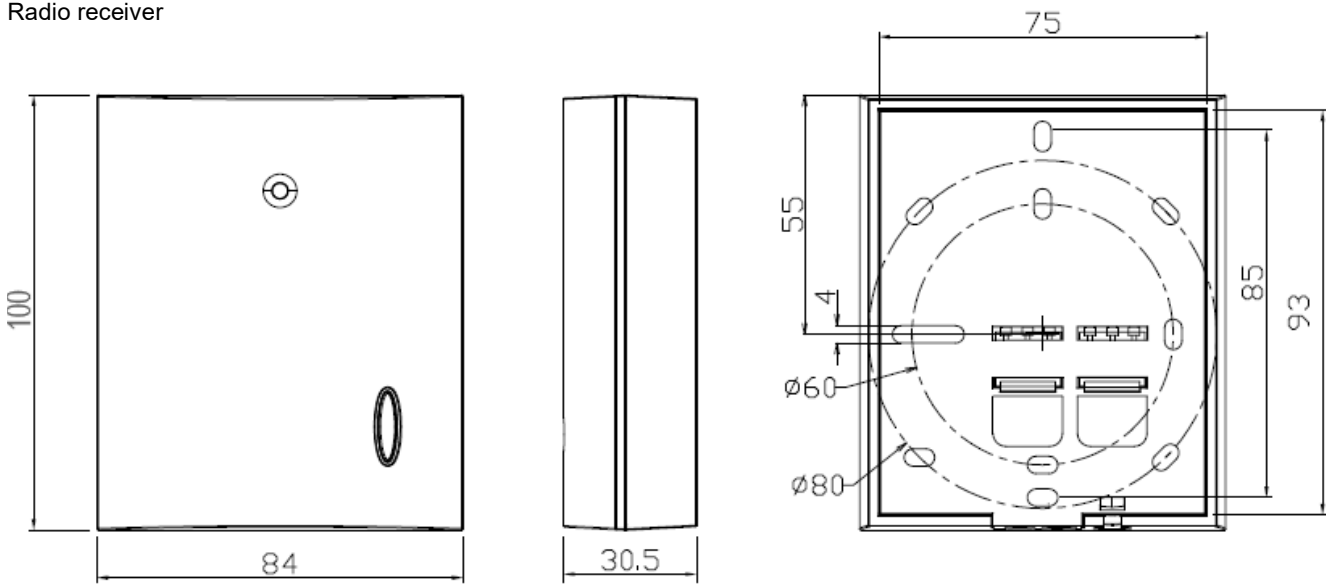

Dimensions in mm

Issued by
Siemens Switzerland Ltd
Smart Infrastructure
Global Headquarters
Theilerstrasse 1a
CH-6300 Zug
+41 58 724 2424
www.siemens.com/buildingtechnologies

© Siemens Switzerland Ltd, 2022
Technical specifications and availability subject to change without notice.

Document ID A6V13156971_en--_a
Edition 2022-04-14