

# NH fuse-links gG 500VAC

double indicator/live gripping-lugs size 000, 00, 0, 1, 2, 3

## LOW VOLTAGE IEC FUSES

### IEC NH FUSE-LINKS



The NH system is classified among plug-in fuse systems and is composed of:

- fuse-base (possibly including terminal covers and phase barriers)
- fuse-link with blade contact
- fuse-link replacement device (LV HRC fuse puller)

Since the design of this system cannot guarantee non-interchangeability of rated current it must be handled by a qualified professional.

Type “gG” NH fuse-links are full range breaking capacity fuse-links and are used to protect cables and equipment. They can interrupt any current surge, from the lowest fusing current up to their breaking capacity, and so can be used alone as protection. They also protect electrical devices and industrial set-ups from the electrodynamic effects of very high short-circuit currents.

## TECHNICAL DATA OVERVIEW

Voltage AC	500 VAC
Voltage DC	250 VDC
Ampere Range (A)	2 ... 800 A
Size per Standard	000, 00, 0, 1, 2, 3
Speed/Characteristic	gG
I.R. AC (IEC)	120 kA
I.R. DC (IEC)	80 kA
Body Material	ceramic
Contact Materials	copper, silver-plated

## FEATURES & BENEFITS

- Dimensions according to DIN 43 620 parts 1 to 4
- Non-isolated gripping lugs
- Double indicator
- Lead free contact blades
- 0% cadmium

## APPLICATIONS

- gG: general purpose cable and line protection

## STANDARDS

- VDE 0636 Part 201
- IEC 60269-1 and -2



MERSEN reserves the right to change, update or correct, without notice, any information contained in this datasheet.

# NH fuse-links gG 500VAC

double indicator/live gripping-lugs size 000, 00, 0, 1, 2, 3

## PRODUCT RANGE



NH000GG50V2

### Size 000 gG 500VAC

Catalog number	Item number	Rated voltage AC (IEC)	Rated voltage DC (IEC)	Rated current I <sub>n</sub>	Power dissipation at I <sub>n</sub>	Package	Weight
NH000GG50V2	B211946	500 V	250 V	2 A	1.9 W	3	0.13 kg
NH000GG50V4	M212462	500 V	250 V	4 A	1.5 W	3	0.13 kg
NH000GG50V6	D213995	500 V	250 V	6 A	1.6 W	3	0.13 kg
NH000GG50V10	B219651	500 V	250 V	10 A	1.1 W	3	0.13 kg
NH000GG50V16	K222097	500 V	250 V	16 A	1.8 W	9	0.13 kg
NH000GG50V20	A222847	500 V	250 V	20 A	2.3 W	9	0.13 kg
NH000GG50V25	E201185	500 V	250 V	25 A	2.4 W	9	0.13 kg
NH000GG50V32	Z211438	500 V	250 V	32 A	3.1 W	9	0.13 kg
NH000GG50V35	C211947	500 V	250 V	35 A	3 W	9	0.13 kg
NH000GG50V40	N212463	500 V	250 V	40 A	3.7 W	9	0.13 kg
NH000GG50V50	T212974	500 V	250 V	50 A	4.1 W	9	0.13 kg
NH000GG50V63	E213996	500 V	250 V	63 A	5.4 W	9	0.13 kg
NH000GG50V80	Y216543	500 V	250 V	80 A	6.5 W	9	0.13 kg
NH000GG50V100	B219122	500 V	250 V	100 A	7.5 W	9	0.13 kg



NH00GG50V125

### Size 00 gG 500VAC

Catalog number	Item number	Rated voltage AC (IEC)	Rated voltage DC (IEC)	Rated current I <sub>n</sub>	Power dissipation at I <sub>n</sub>	Package	Weight
NH00GG50V125	R201863	500 V	250 V	125 A	10 W	3	0.2 kg
NH00GG50V160	P211084	500 V	250 V	160 A	11.3 W	3	0.2 kg



NH0GG50V6

### Size 0 gG 500VAC

Catalog number	Item number	Rated voltage AC (IEC)	Rated voltage DC (IEC)	Rated current I <sub>n</sub>	Power dissipation at I <sub>n</sub>	Package	Weight
NH0GG50V6	H213148	500 V	250 V	6 A	1.6 W	3	0.27 kg
NH0GG50V10	G214159	500 V	250 V	10 A	1.1 W	3	0.27 kg
NH0GG50V16	Q215179	500 V	250 V	16 A	1.8 W	3	0.27 kg
NH0GG50V20	R215686	500 V	250 V	20 A	2.3 W	3	0.27 kg
NH0GG50V25	Y216198	500 V	250 V	25 A	2.4 W	3	0.27 kg
NH0GG50V32	W216702	500 V	250 V	32 A	3.1 W	3	0.27 kg
NH0GG50V35	J217220	500 V	250 V	35 A	3 W	3	0.27 kg
NH0GG50V40	P217731	500 V	250 V	40 A	3.7 W	3	0.27 kg
NH0GG50V50	Z218246	500 V	250 V	50 A	4.1 W	3	0.27 kg
NH0GG50V63	N218765	500 V	250 V	63 A	6.6 W	3	0.27 kg
NH0GG50V80	C219284	500 V	250 V	80 A	8 W	3	0.27 kg
NH0GG50V100	D219814	500 V	250 V	100 A	9.4 W	3	0.27 kg
NH0GG50V125	P222492	500 V	250 V	125 A	11.8 W	3	0.27 kg
NH0GG50V160	F223013	500 V	250 V	160 A	14.6 W	3	0.27 kg
NH0GG50V200	C229611	500 V	250 V	200 A	18.1 W	3	0.27 kg
NH0GG50V224	D229612	500 V	250 V	224 A	19.2 W	3	0.27 kg
NH0GG50V250	E229613	500 V	250 V	250 A	20.3 W	3	0.27 kg

# NH fuse-links gG 500VAC

double indicator/live gripping-lugs size 000, 00, 0, 1, 2, 3

## PRODUCT RANGE



NH1GG50V16

### Size 1 gG 500VAC

Catalog number	Item number	Rated voltage AC (IEC)	Rated voltage DC (IEC)	Rated current I <sub>n</sub>	Power dissipation at I <sub>n</sub>	Width	Package	Weight
NH1GG50V16	M200801	500 V	250 V	16 A	1.8 W	29.5 mm	3	0.28 kg
NH1GG50V20	C201344	500 V	250 V	20 A	2.3 W	29.5 mm	3	0.28 kg
NH1GG50V25	N201860	500 V	250 V	25 A	2.4 W	29.5 mm	3	0.28 kg
NH1GG50V32	L211081	500 V	250 V	32 A	3.1 W	29.5 mm	3	0.28 kg
NH1GG50V35	A211600	500 V	250 V	35 A	3 W	29.5 mm	3	0.28 kg
NH1GG50V40	Y212633	500 V	250 V	40 A	3.7 W	29.5 mm	3	0.28 kg
NH1GG50V50	B213648	500 V	250 V	50 A	4.1 W	29.5 mm	3	0.28 kg
NH1GG50V63	L214669	500 V	250 V	63 A	6.6 W	29.5 mm	3	0.28 kg
NH1GG50V80	S215687	500 V	250 V	80 A	8 W	29.5 mm	3	0.28 kg
NH1GG50V100	X216703	500 V	250 V	100 A	9.4 W	29.5 mm	3	0.28 kg
NH1GG50V125	V236044	500 V	250 V	125 A	11.8 W	29.5 mm	3	0.28 kg
NH1GG50V160	A218247	500 V	250 V	160 A	14.6 W	39.5 mm	3	0.42 kg
NH1GG50V200	P218766	500 V	250 V	200 A	18 W	39.5 mm	3	0.42 kg
NH1GG50V224	D219285	500 V	250 V	224 A	19 W	39.5 mm	3	0.42 kg
NH1GG50V250	E219815	500 V	250 V	250 A	20 W	39.5 mm	3	0.42 kg
NH1GG50V315	Q228519	500 V	250 V	315 A	20.5 W	39.5 mm	3	0.42 kg
NH1GG50V355	R228520	500 V	250 V	355 A	23.7 W	39.5 mm	3	0.42 kg



NH2GG50V63

### Size 2 gG 500VAC

Catalog number	Item number	Rated voltage AC (IEC)	Rated voltage DC (IEC)	Rated current I <sub>n</sub>	Power dissipation at I <sub>n</sub>	Width	Package	Weight
NH2GG50V25	N200802	500 V	250 V	25 A	2.4 W	39.5 mm	3	0.42 kg
NH2GG50V32	D201345	500 V	250 V	32 A	3.1 W	39.5 mm	3	0.42 kg
NH2GG50V35	P201861	500 V	250 V	35 A	3 W	39.5 mm	3	0.42 kg
NH2GG50V40	M211082	500 V	250 V	40 A	3.7 W	39.5 mm	3	0.42 kg
NH2GG50V50	B211601	500 V	250 V	50 A	4.1 W	39.5 mm	3	0.42 kg
NH2GG50V63	Z212634	500 V	250 V	63 A	6.8 W	39.5 mm	3	0.42 kg
NH2GG50V80	C213649	500 V	250 V	80 A	8.3 W	39.5 mm	3	0.42 kg
NH2GG50V100	M214670	500 V	250 V	100 A	10.7 W	39.5 mm	3	0.42 kg
NH2GG50V125	T215688	500 V	250 V	125 A	12.2 W	39.5 mm	3	0.42 kg
NH2GG50V160	Y216704	500 V	250 V	160 A	15 W	39.5 mm	3	0.42 kg
NH2GG50V200	R217733	500 V	250 V	200 A	18.5 W	39.5 mm	3	0.42 kg
NH2GG50V224	Q218767	500 V	250 V	224 A	19.2 W	39.5 mm	3	0.42 kg
NH2GG50V250	R222494	500 V	250 V	250 A	20.6 W	39.5 mm	3	0.42 kg
NH2GG50V300	P200803	500 V	250 V	300 A	21 W	51 mm	3	0.64 kg
NH2GG50V315	E201346	500 V	250 V	315 A	25 W	51 mm	3	0.64 kg
NH2GG50V355	Q201862	500 V	250 V	355 A	31.5 W	51 mm	3	0.64 kg
NH2GG50V400	N211083	500 V	250 V	400 A	32 W	51 mm	3	0.64 kg
NH2GG50V425	S228521	500 V	250 V	425 A	32.2 W	51 mm	3	0.64 kg
NH2GG50V500	T228522	500 V	250 V	500 A	35.6 W	51 mm	3	0.64 kg

MERSEN reserves the right to change, update or correct, without notice, any information contained in this datasheet.

# NH fuse-links gG 500VAC

double indicator/live gripping-lugs size 000, 00, 0, 1, 2, 3

## PRODUCT RANGE

### Size 3 gG 500VAC



NH3GG50V250



NH3GG50V800

Catalog number	Item number	Rated voltage AC (IEC)	Rated voltage DC (IEC)	Rated current I <sub>n</sub>	Power dissipation at I <sub>n</sub>	Width	Package	Weight
NH3GG50V63	R1069078	500 V	250 V	63 A	6.8 W	51 mm	1	0.65 kg
NH3GG50V80	S1069079	500 V	250 V	80 A	8.3 W	51 mm	1	0.65 kg
NH3GG50V100	S235168	500 V	250 V	100 A	10.7 W	51 mm	1	0.65 kg
NH3GG50V125	T235169	500 V	250 V	125 A	12.2 W	51 mm	1	0.65 kg
NH3GG50V160	V235170	500 V	250 V	160 A	15 W	51 mm	1	0.65 kg
NH3GG50V200	W235171	500 V	250 V	200 A	18.5 W	51 mm	1	0.65 kg
NH3GG50V224	V233744	500 V	250 V	224 A	20 W	51 mm	1	0.65 kg
NH3GG50V250	C211602	500 V	250 V	250 A	21.1 W	51 mm	1	0.65 kg
NH3GG50V300	A212635	500 V	250 V	300 A	20 W	51 mm	1	0.65 kg
NH3GG50V315	L213151	500 V	250 V	315 A	25 W	51 mm	1	0.65 kg
NH3GG50V355	K214162	500 V	250 V	355 A	32 W	51 mm	1	0.65 kg
NH3GG50V400	T215182	500 V	250 V	400 A	34 W	51 mm	1	0.65 kg
NH3GG50V425	B216201	500 V	250 V	425 A	34 W	70 mm	1	1.05 kg
NH3GG50V450	Z216705	500 V	250 V	450 A	38 W	70 mm	1	1.05 kg
NH3GG50V500	M217223	500 V	250 V	500 A	43 W	70 mm	1	1.05 kg
NH3GG50V630	S217734	500 V	250 V	630 A	43.1 W	70 mm	1	1.05 kg
NH3GG50V800	V228523	500 V	250 V	800 A	53.2 W	70 mm	1	1.05 kg

## TECHNICAL DATA

	Size 000	Size 00	Size 0	Size 1	Size 2	Size 3
Size	000	00	0	1	2	3
Rated current	2 ... 100 A	125 ... 160 A	6 ... 250 A	16 ... 355 A	25 ... 500 A	63 ... 800 A
Rated breaking capacity AC	120 kA	120 kA	120 kA	120 kA	120 kA	120 kA
Rated voltage AC	500 V	500 V	500 V	500 V	500 V	500 V
Rated voltage DC	250 V	250 V	250 V	250 V	250 V	250 V
Indication System	double indicator	double indicator	double indicator	double indicator	double indicator	double indicator
Width	21 mm	30 mm	30 mm	40 mm	52 mm	72 mm

MERSEN reserves the right to change, update or correct, without notice, any information contained in this datasheet.

## TIME CURRENT CHARACTERISTIC CURVES

Size 000

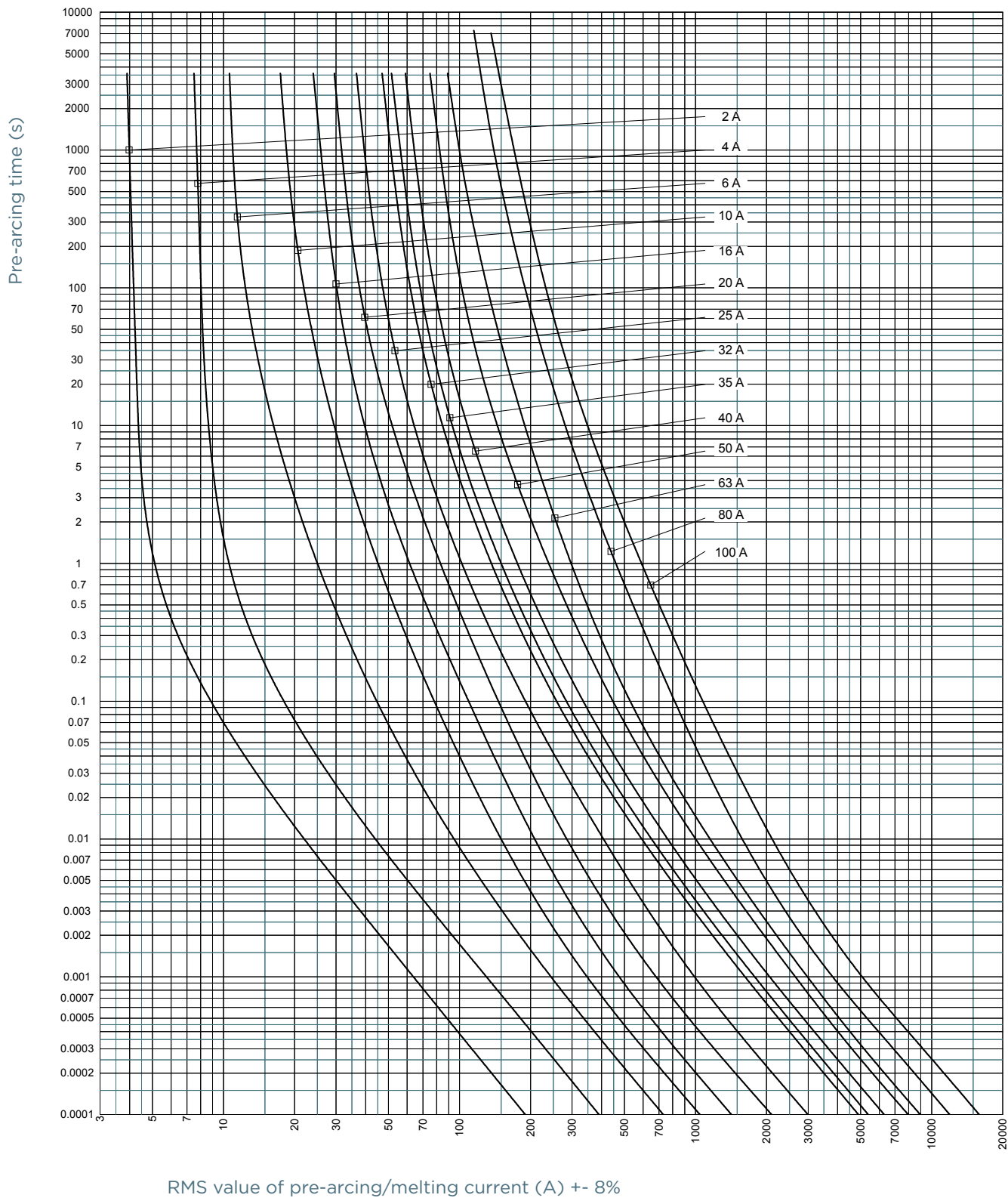

MERSEN reserves the right to change, update or correct, without notice, any information contained in this datasheet.

## TIME CURRENT CHARACTERISTIC CURVES

Size 00

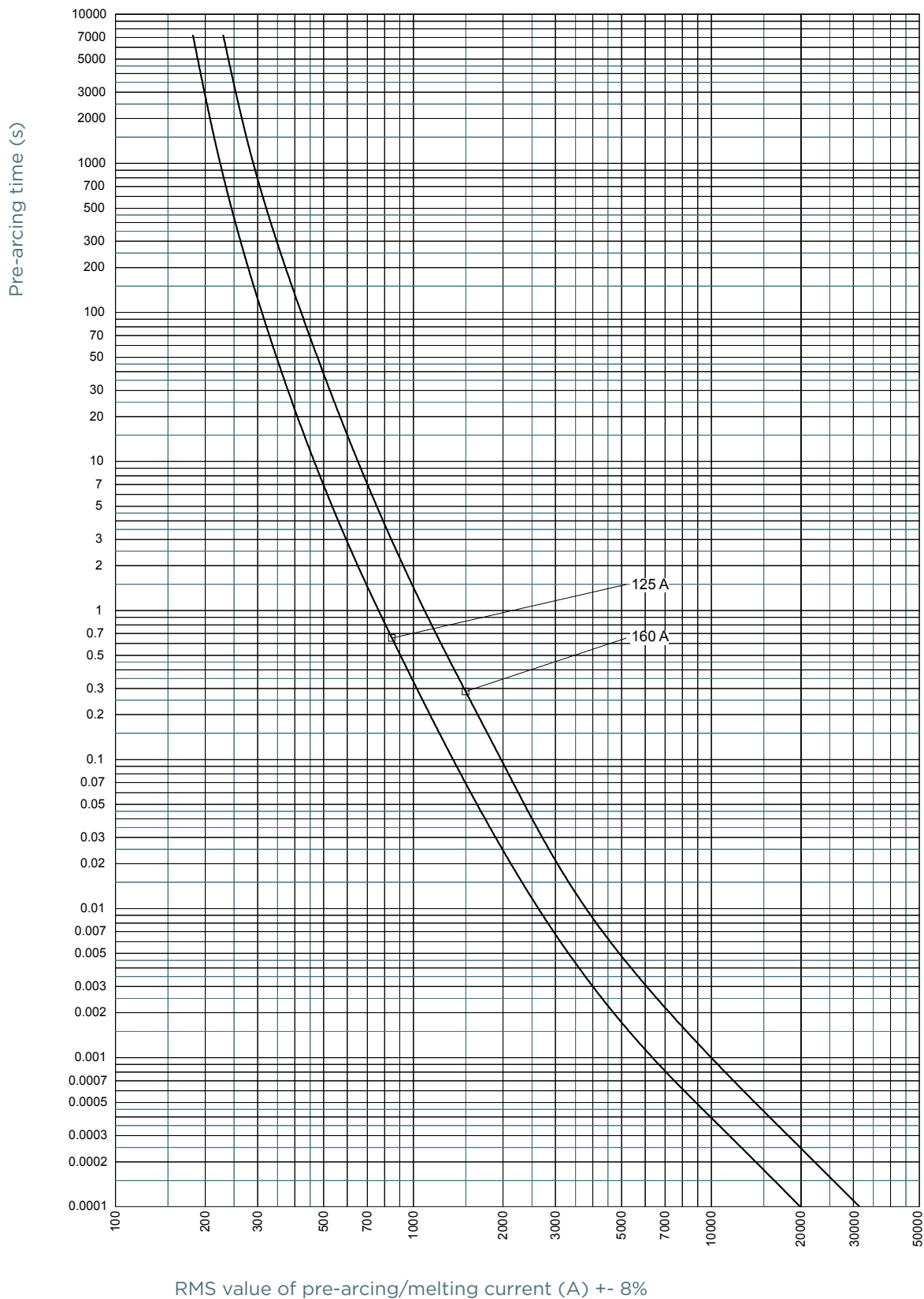

MERSEN reserves the right to change, update or correct, without notice, any information contained in this datasheet.

## TIME CURRENT CHARACTERISTIC CURVES

### Size 0

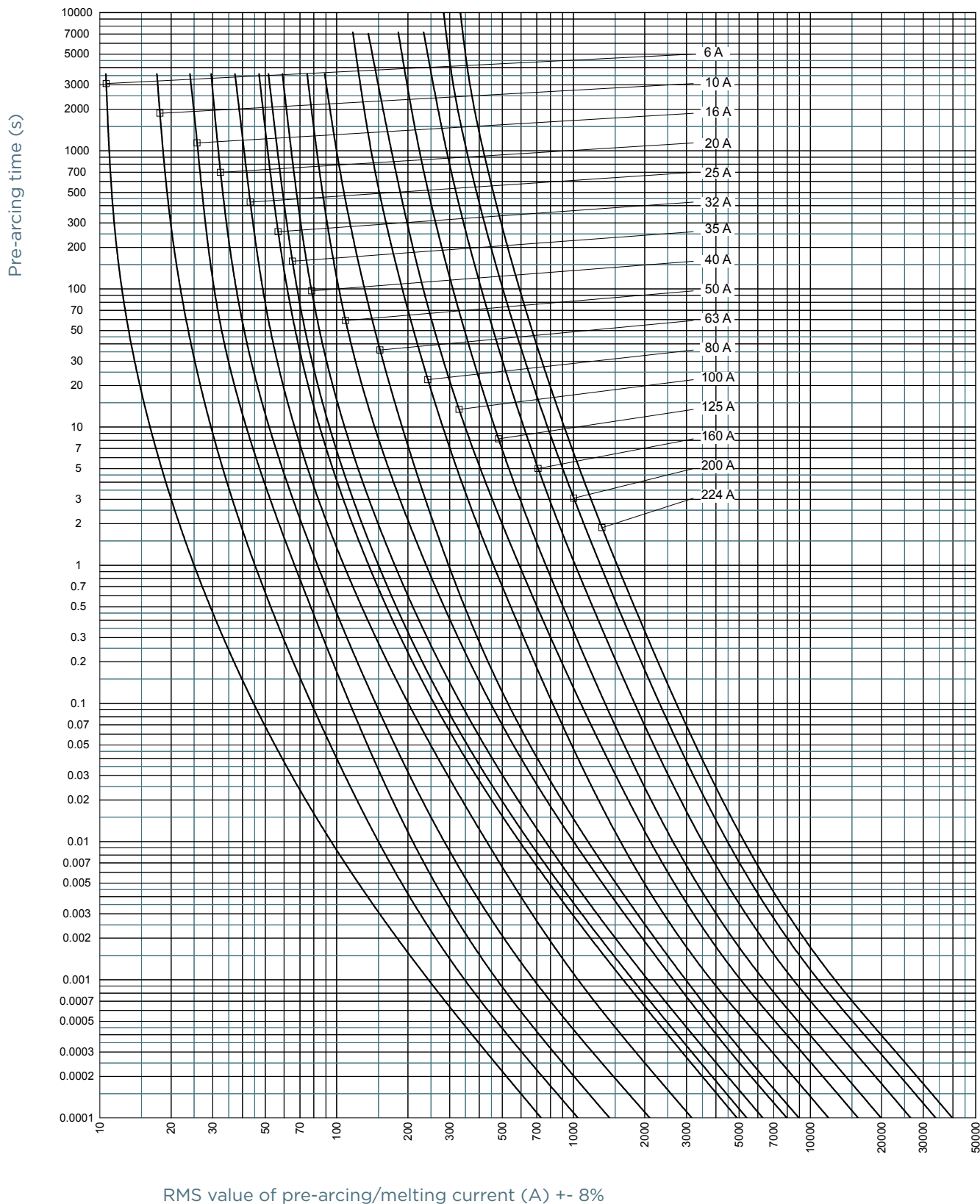

MERSEN reserves the right to change, update or correct, without notice, any information contained in this datasheet.

## TIME CURRENT CHARACTERISTIC CURVES

### Size 0

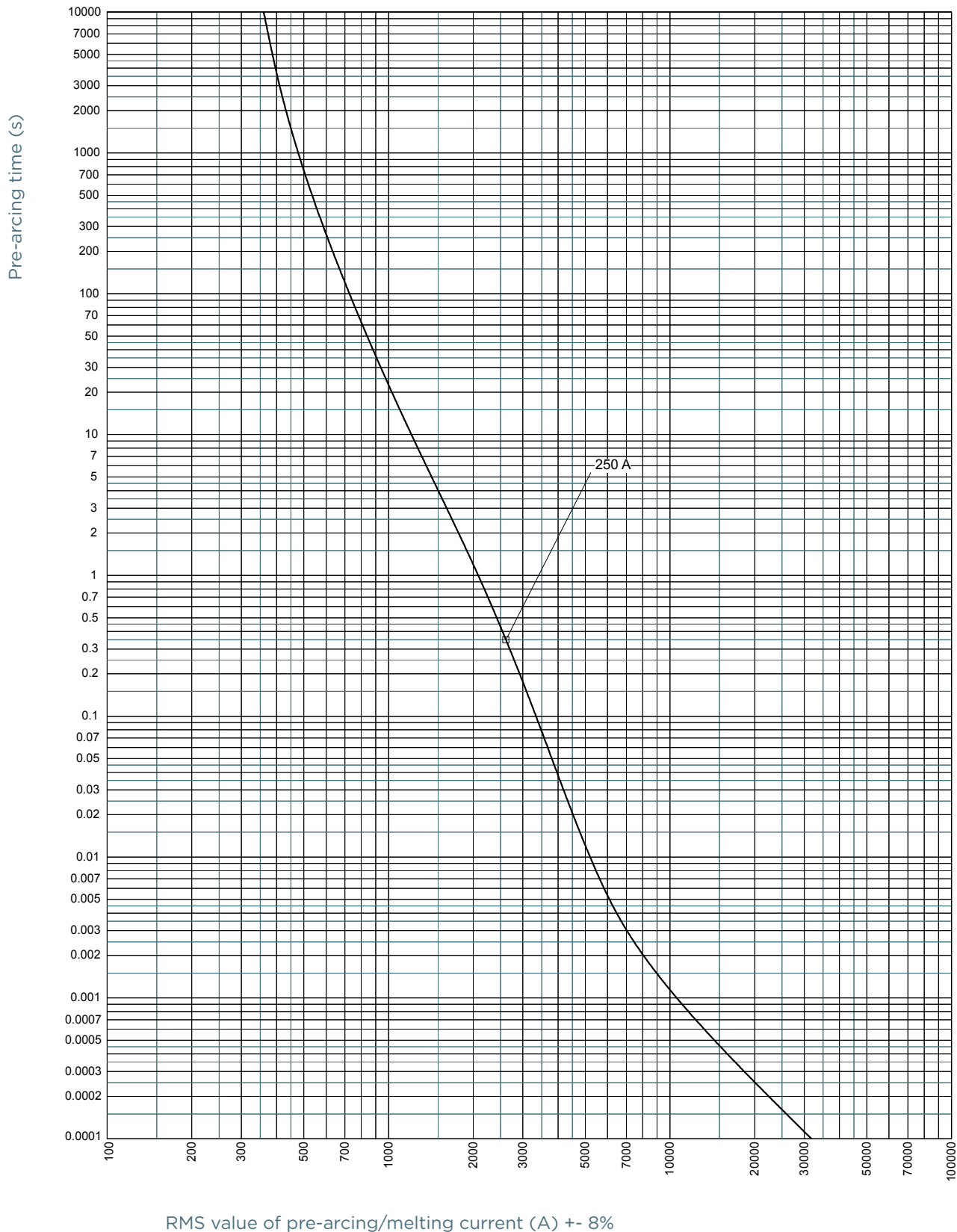

## TIME CURRENT CHARACTERISTIC CURVES

Size 1

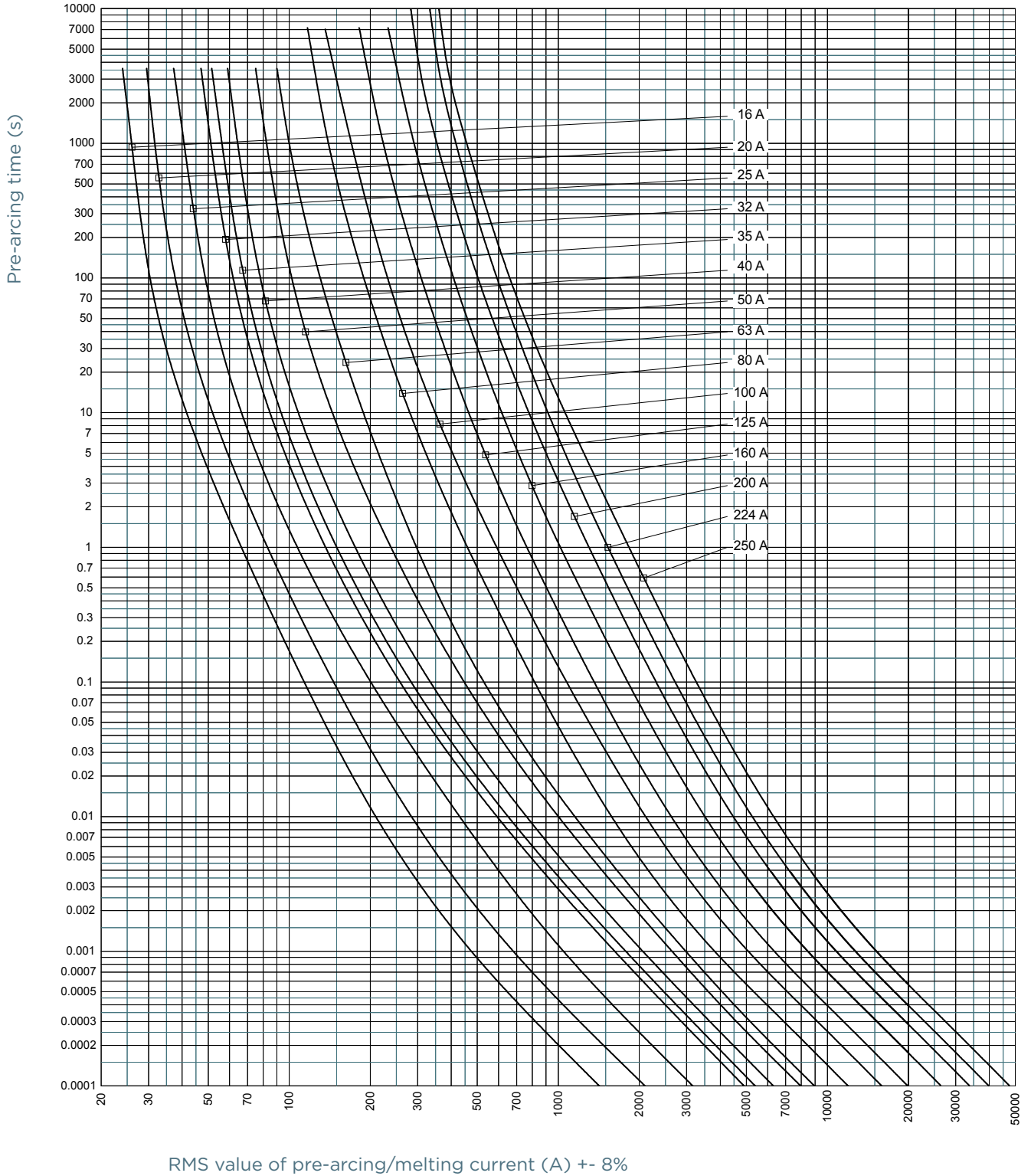

MERSEN reserves the right to change, update or correct, without notice, any information contained in this datasheet.

## TIME CURRENT CHARACTERISTIC CURVES

### Size 1

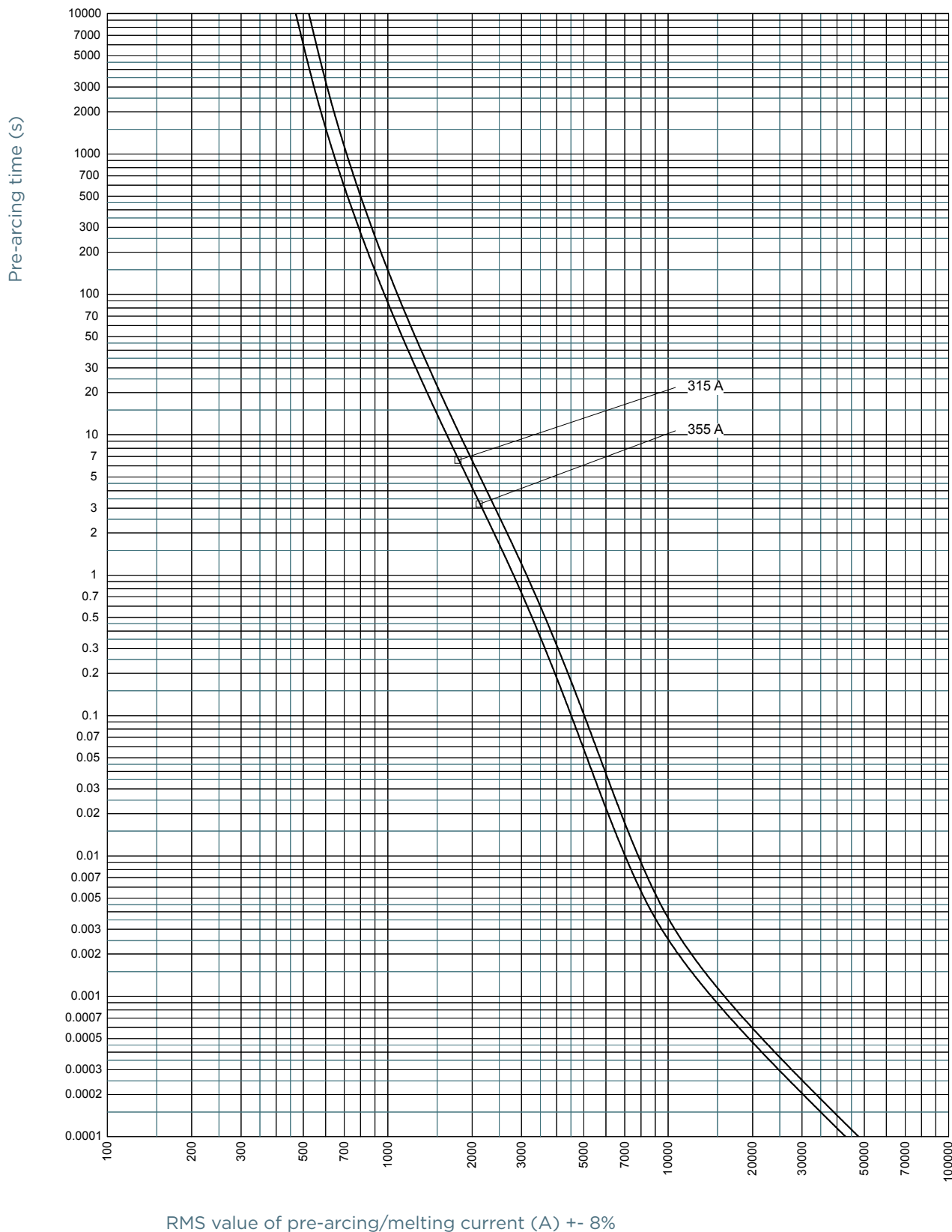

MERSEN reserves the right to change, update or correct, without notice, any information contained in this datasheet.

## TIME CURRENT CHARACTERISTIC CURVES

Size 2

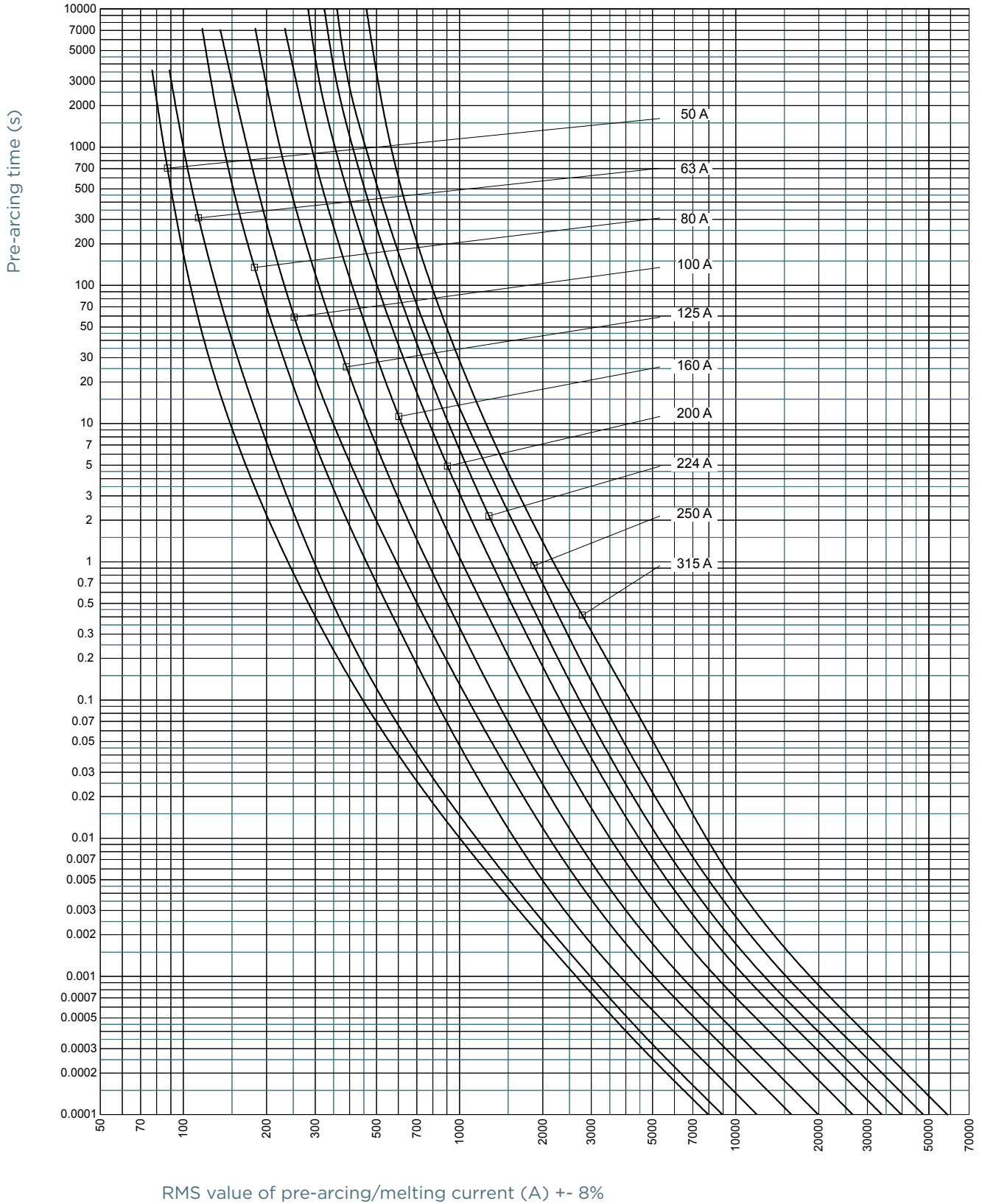

MERSEN reserves the right to change, update or correct, without notice, any information contained in this datasheet.

## TIME CURRENT CHARACTERISTIC CURVES

### Size 2

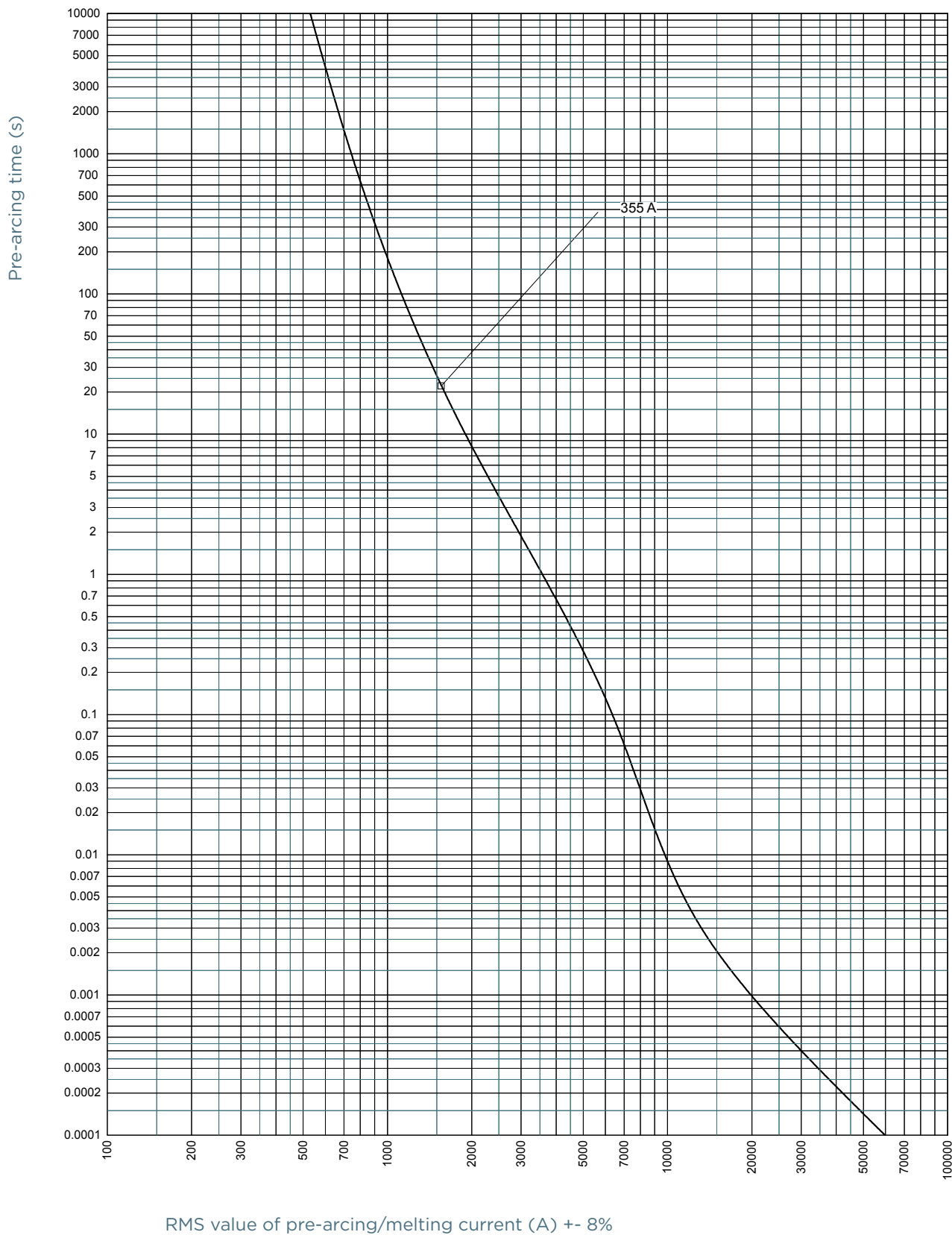

MERSEN reserves the right to change, update or correct, without notice, any information contained in this datasheet.

# NH fuse-links gG 500VAC

double indicator/live gripping-lugs size 000, 00, 0, 1, 2, 3

## TIME CURRENT CHARACTERISTIC CURVES

Size 3

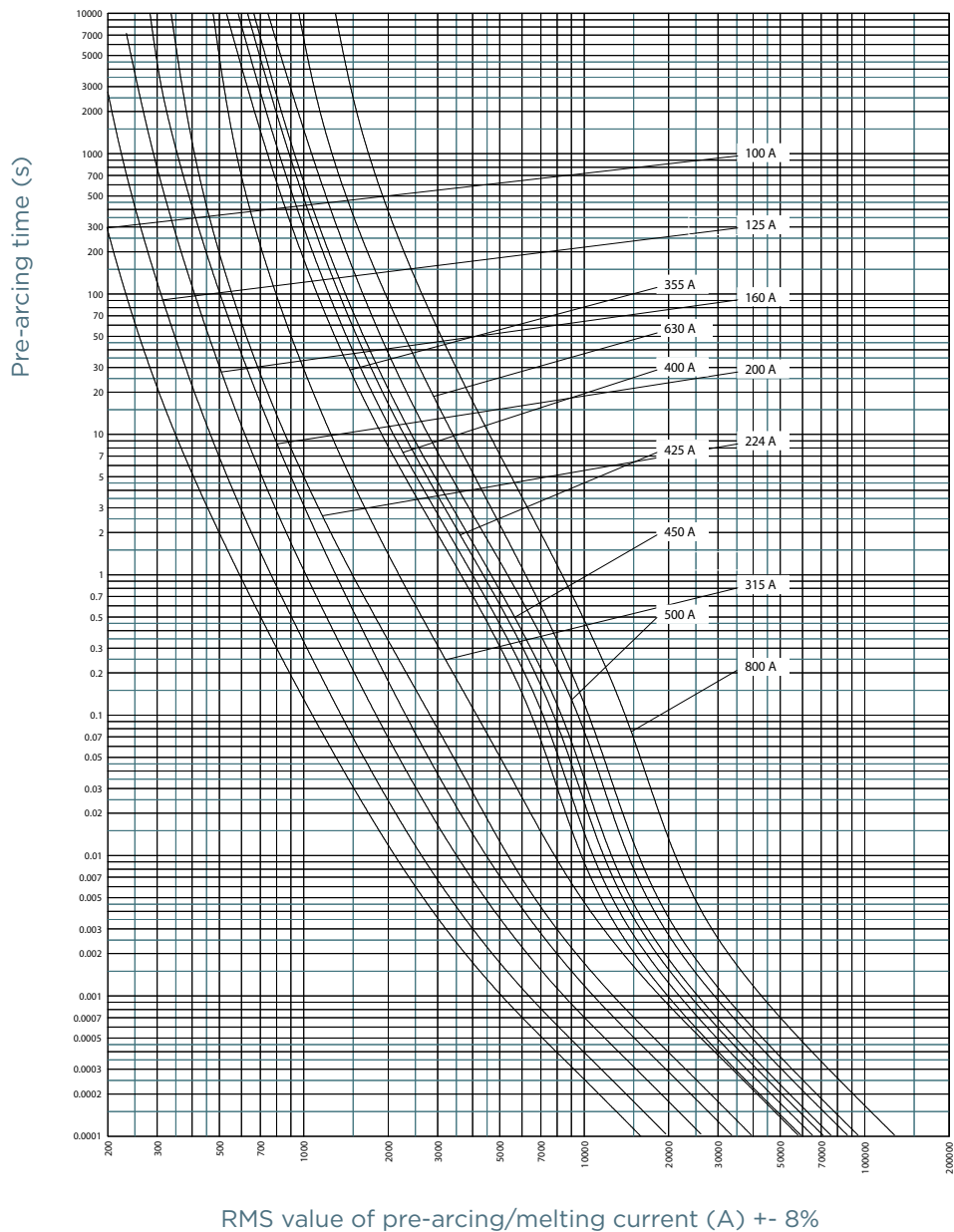

MERSEN reserves the right to change, update or correct, without notice, any information contained in this datasheet.

## CUT-OFF CURRENT CHARACTERISTIC

### Size 000

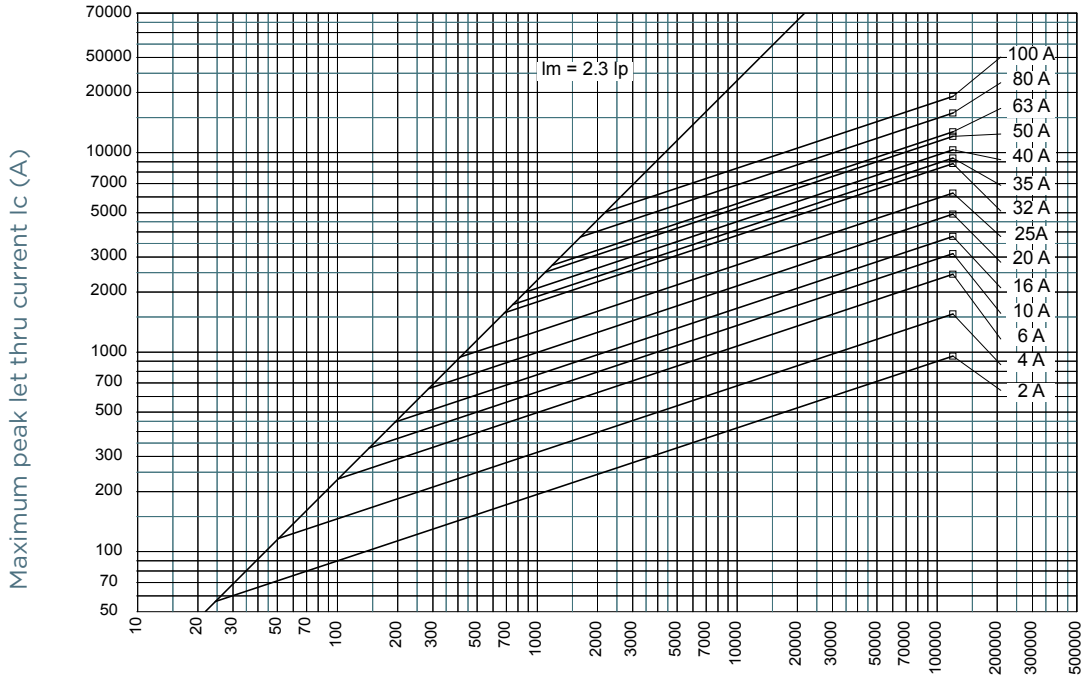

50 Hz RMS symmetrical prospective current  $I_p$  (A)

### Size 00

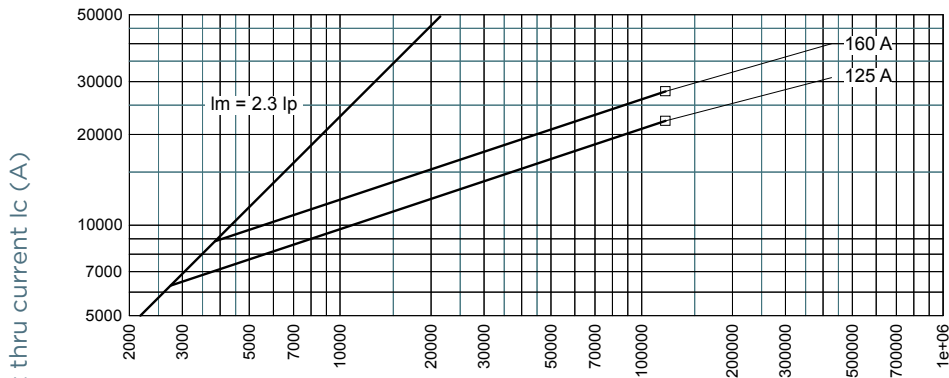

50 Hz RMS symmetrical prospective current  $I_p$  (A)

## CUT-OFF CURRENT CHARACTERISTIC

### Size 0

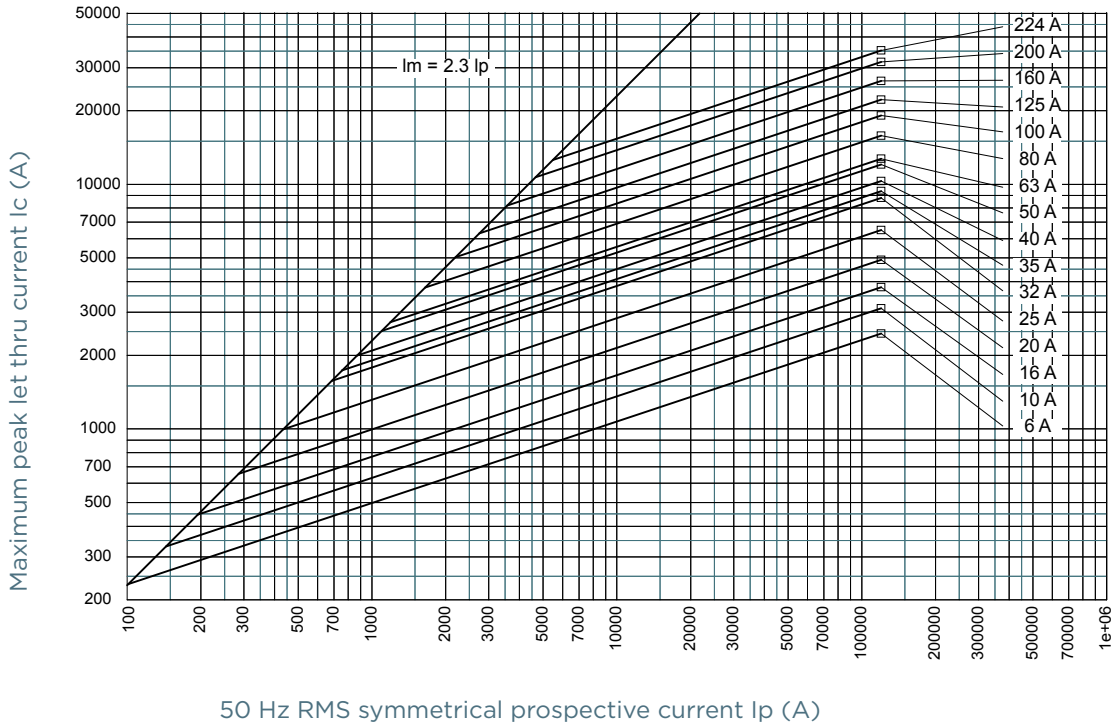

### Size 0

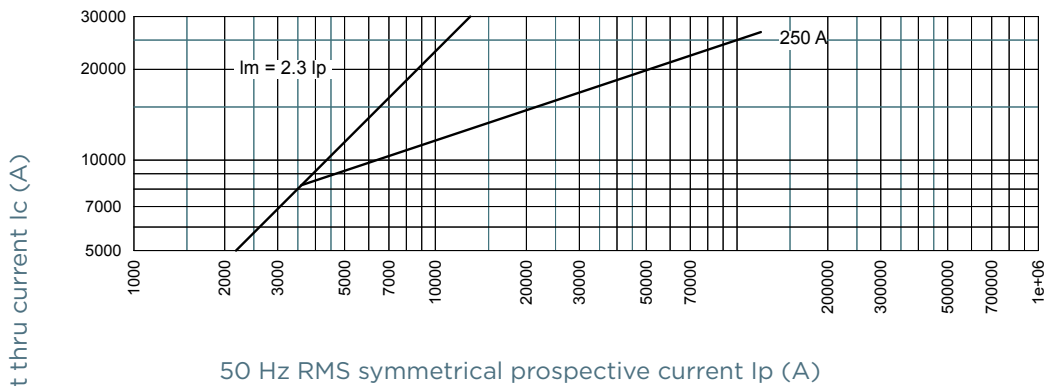

## CUT-OFF CURRENT CHARACTERISTIC

Size 1

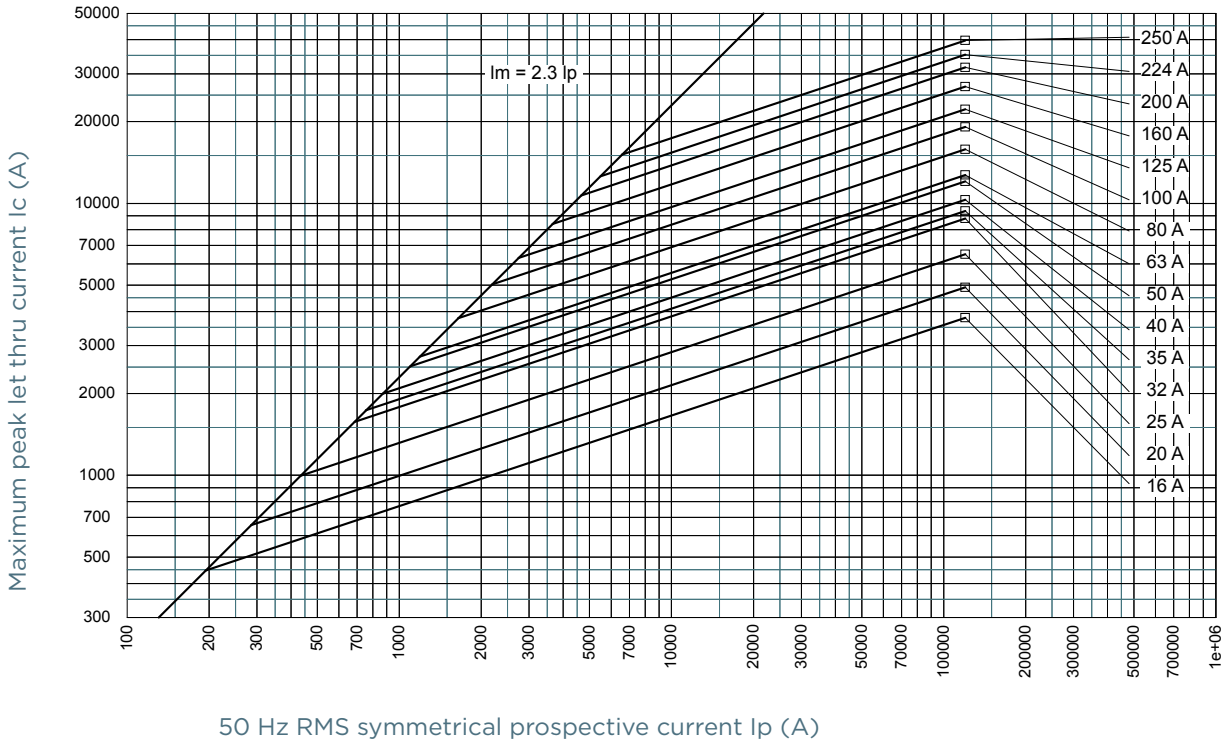

Size 1

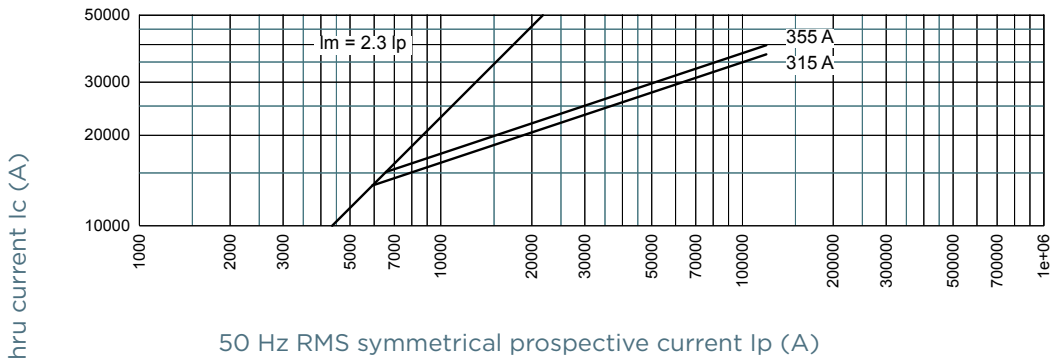

## CUT-OFF CURRENT CHARACTERISTIC

### Size 2

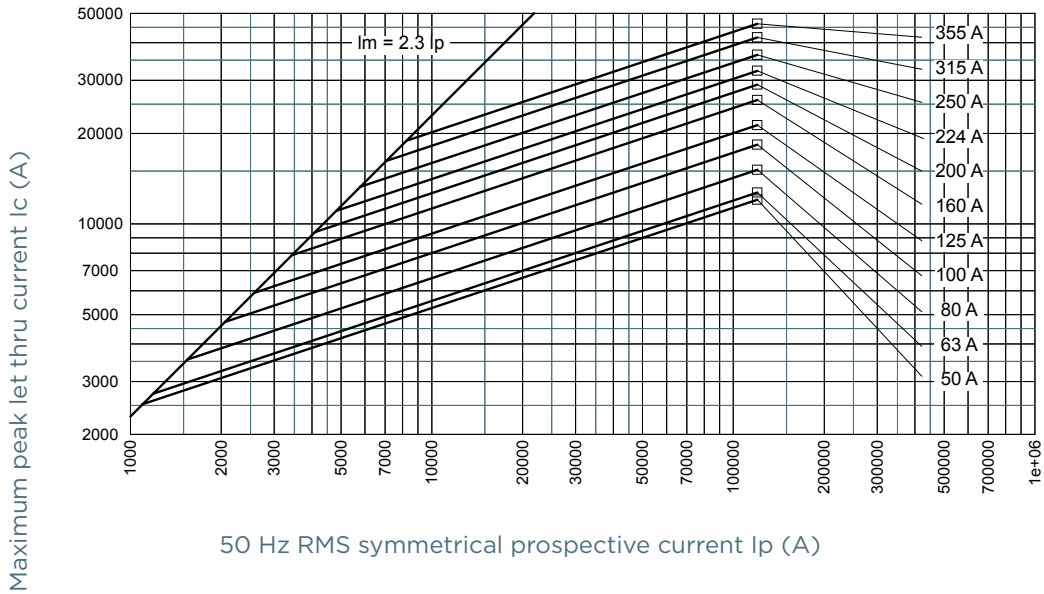

### Size 3

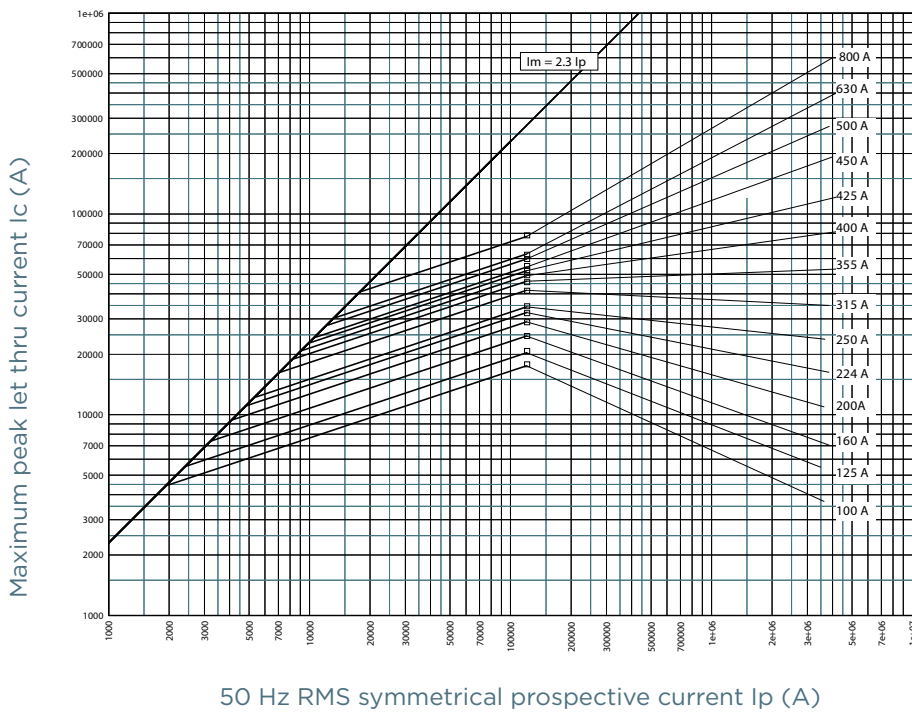

## PRE-ARCING AND OPERATING I<sup>2</sup>t CHARACTERISTICS

### Size 000

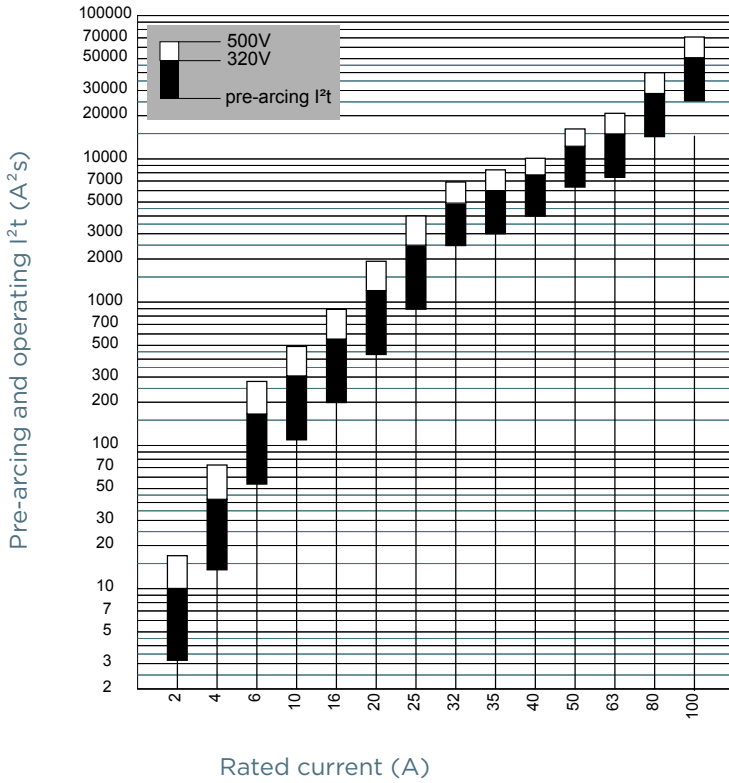

### Size 00

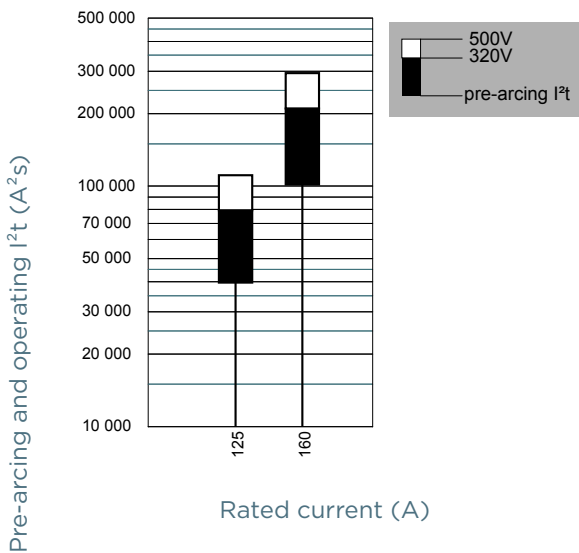

# NH fuse-links gG 500VAC

double indicator/live gripping-lugs size 000, 00, 0, 1, 2, 3

## PRE-ARCING AND OPERATING I<sup>2</sup>t CHARACTERISTICS

Size 0

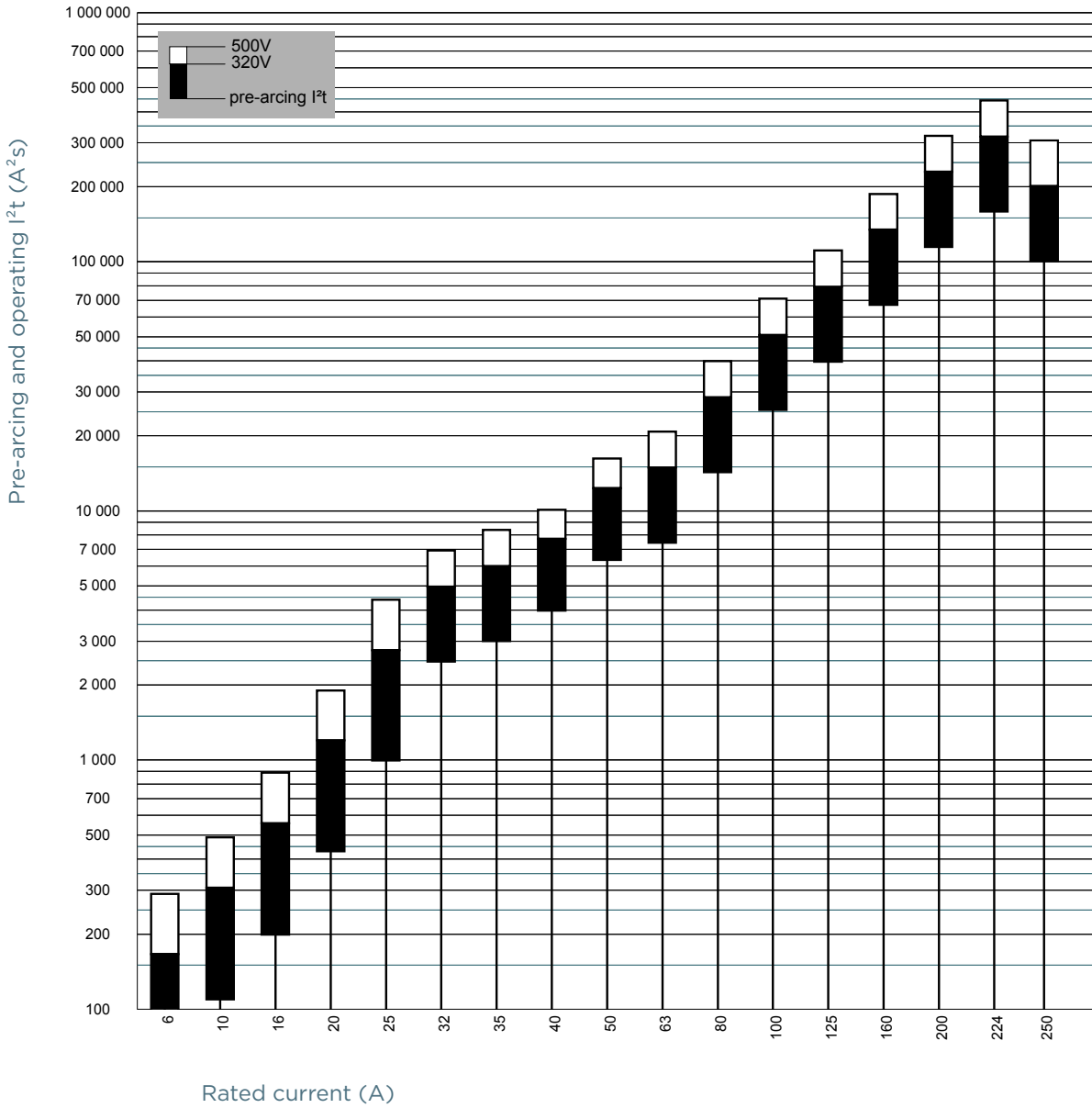

MERSEN reserves the right to change, update or correct, without notice, any information contained in this datasheet.

## PRE-ARCING AND OPERATING I<sup>2</sup>T CHARACTERISTICS

### Size 1

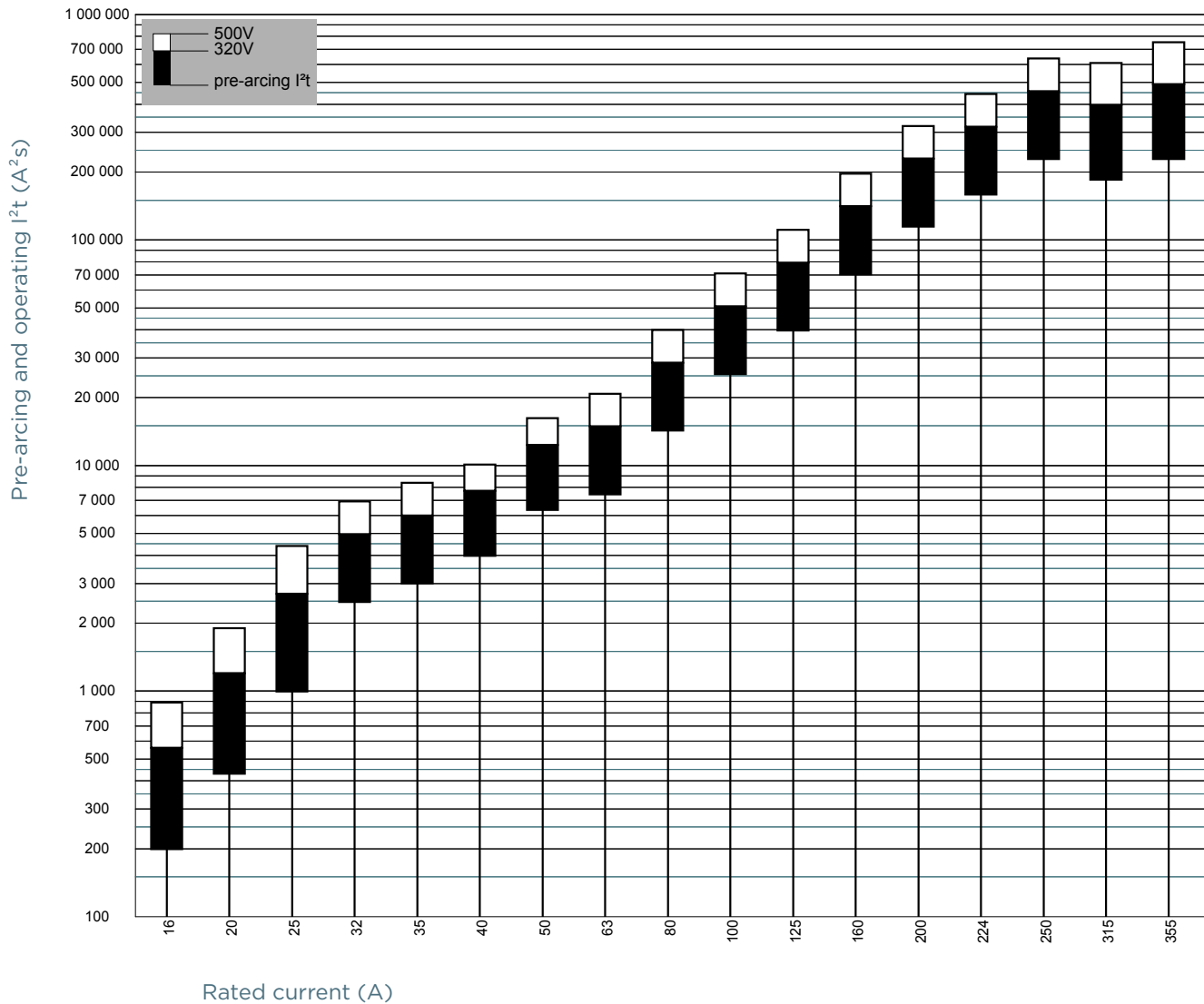

MERSEN reserves the right to change, update or correct, without notice, any information contained in this datasheet.

# NH fuse-links gG 500VAC

double indicator/live gripping-lugs size 000, 00, 0, 1, 2, 3

## PRE-ARCING AND OPERATING $I^2t$ CHARACTERISTICS

Size 2

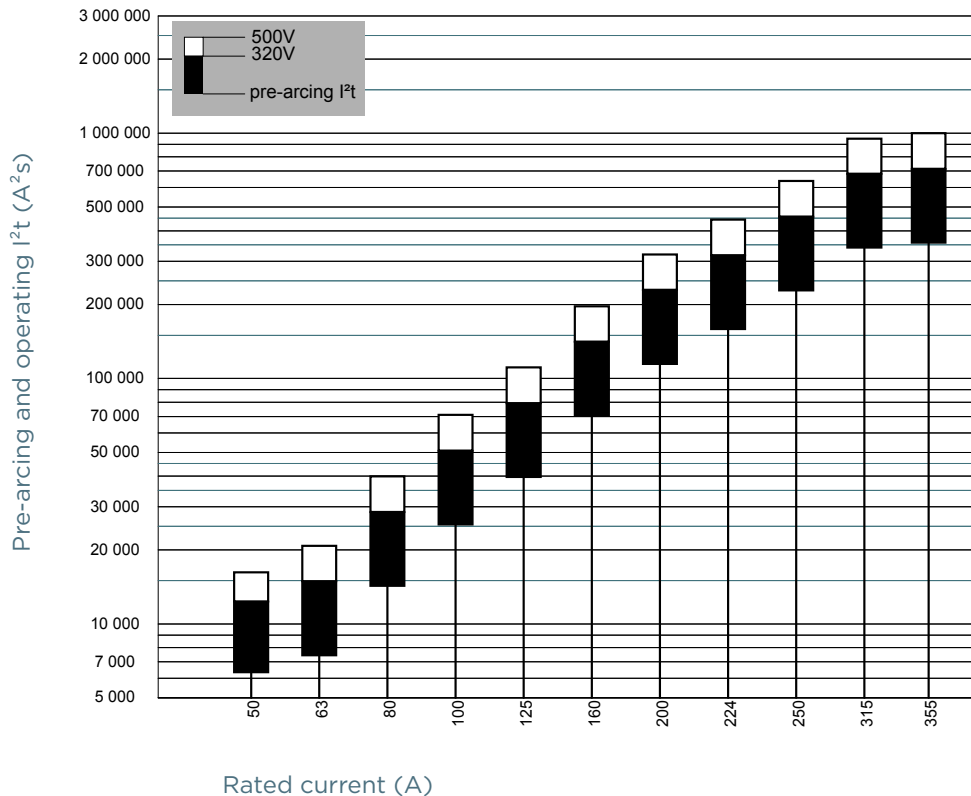

MERSEN reserves the right to change, update or correct, without notice, any information contained in this datasheet.

## PRE-ARCING AND OPERATING I<sup>2</sup>T CHARACTERISTICS

Size 3

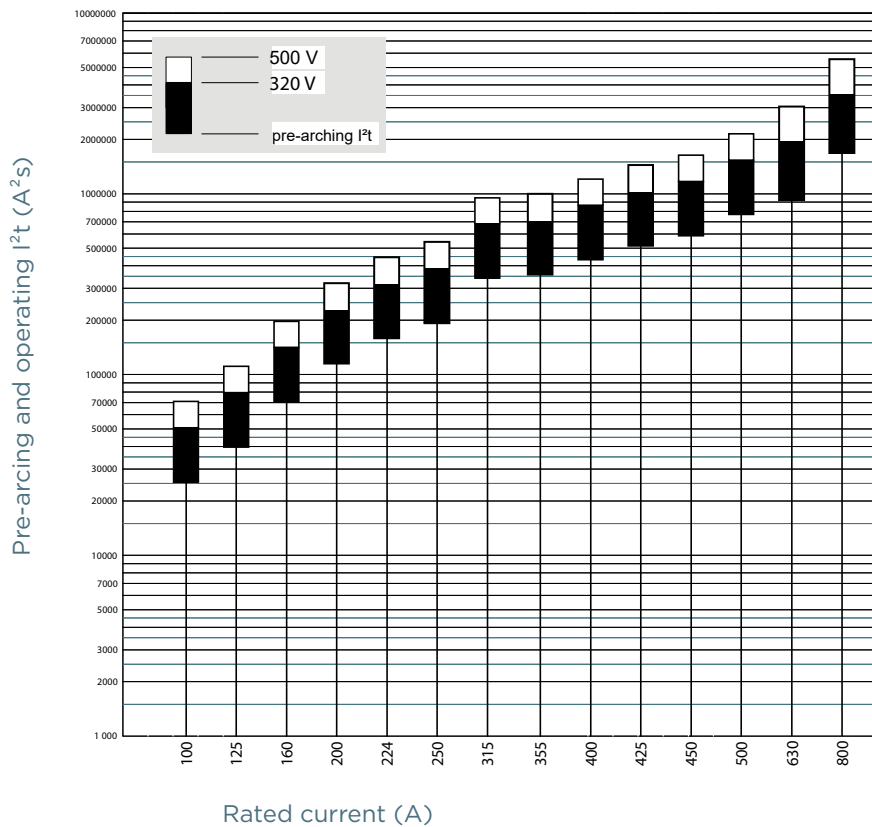

# NH fuse-links gG 500VAC

double indicator/live gripping-lugs size 000, 00, 0, 1, 2, 3

## DIMENSIONS

### Size 000 with double indicator

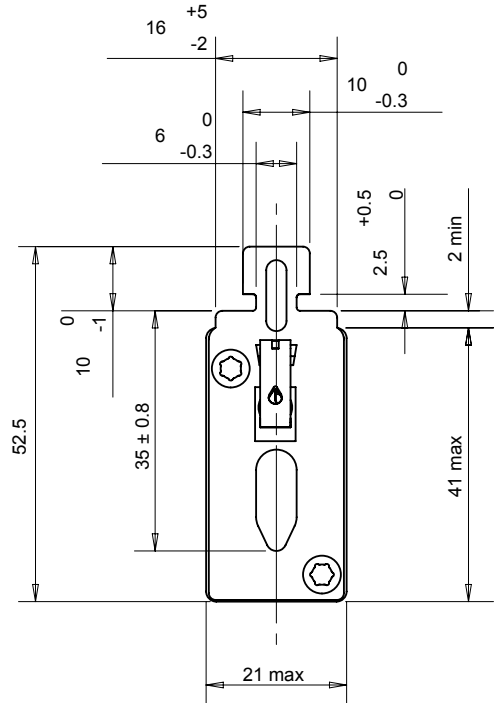
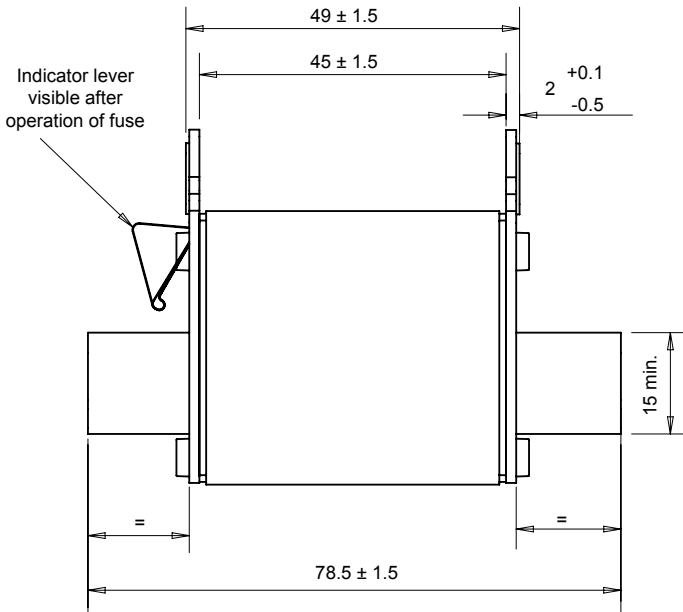

Visibility of red indicator signals conduction of the fuse-link.  
After operation the red indicator is no longer visible

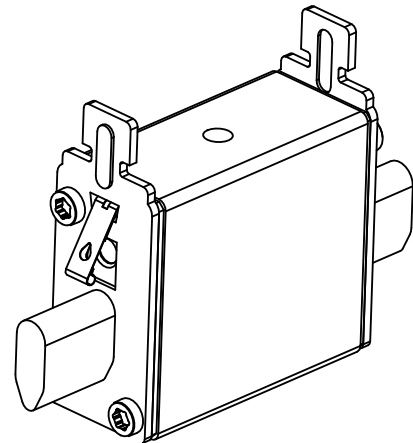
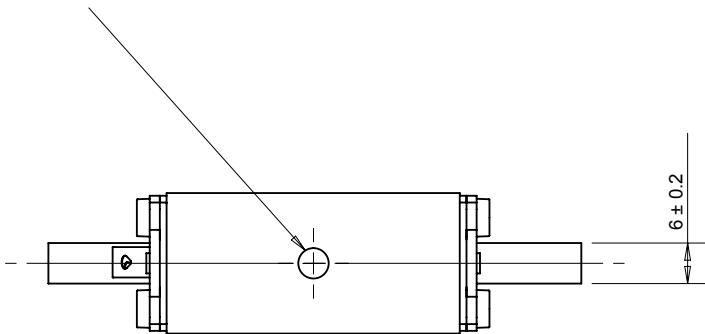

Dimensions in mm

# NH fuse-links gG 500VAC

double indicator/live gripping-lugs size 000, 00, 0, 1, 2, 3

## DIMENSIONS

### Size 00 with double indicator

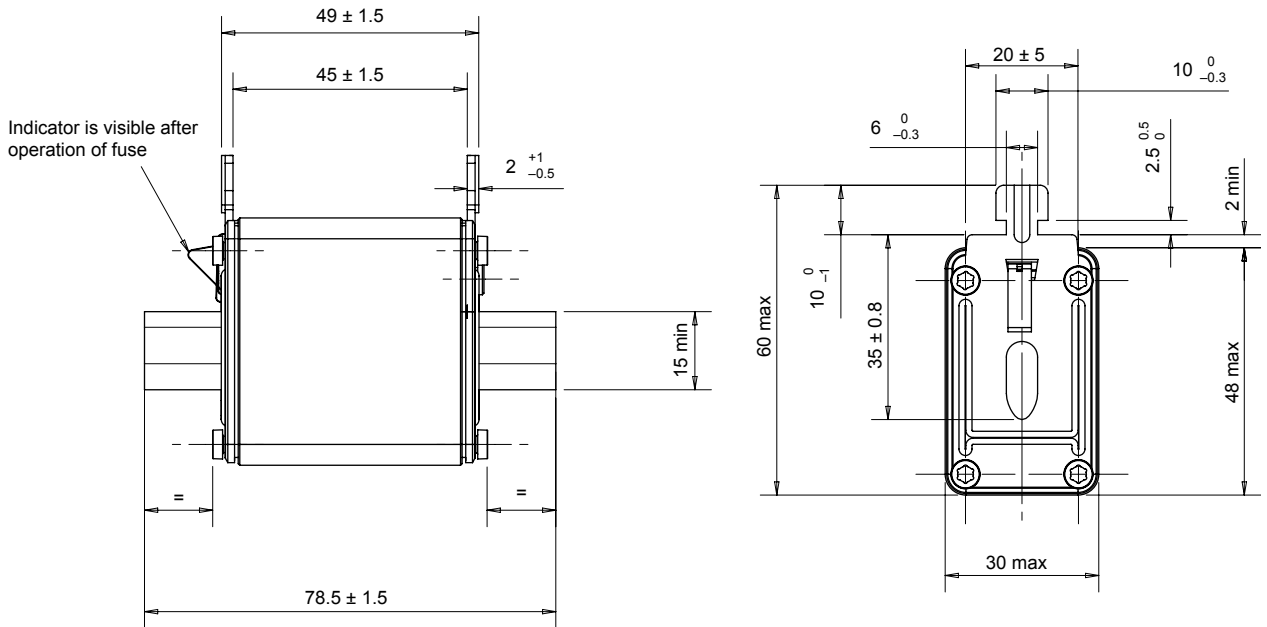

- Visibility of red indicator signals conduction of the fuse-link. After operation the red indicator is no longer visible.

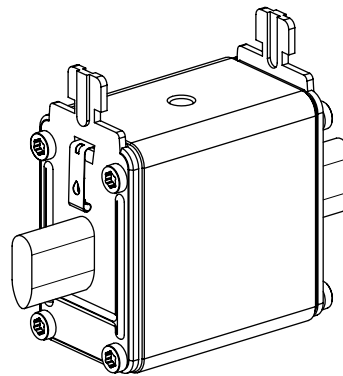
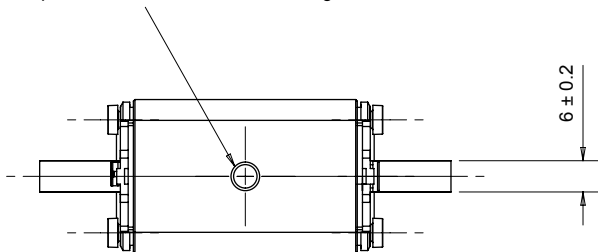

Dimensions in mm

# NH fuse-links gG 500VAC

double indicator/live gripping-lugs size 000, 00, 0, 1, 2, 3

## DIMENSIONS

### Size 0 with double indicator

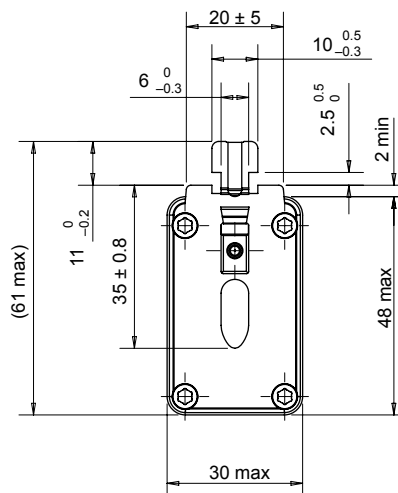
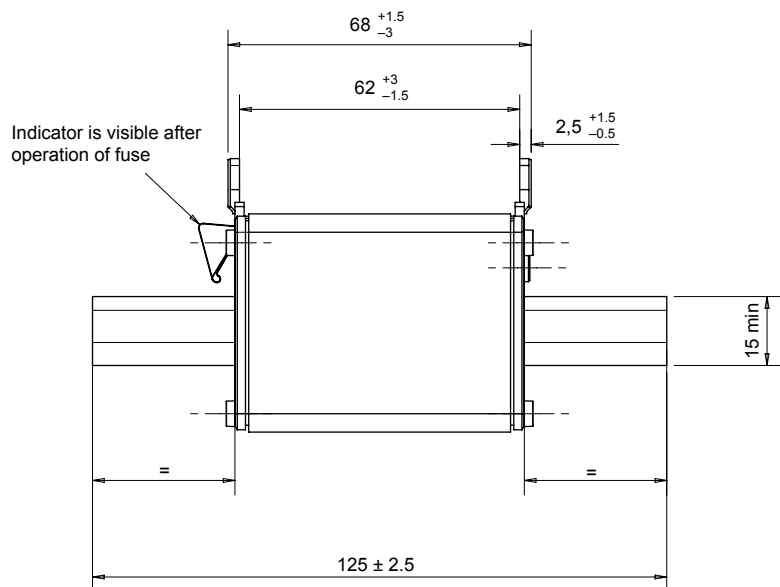

Visibility of red indicator signals conduction of the fuse-link. After operation the red indicator is no longer visible.

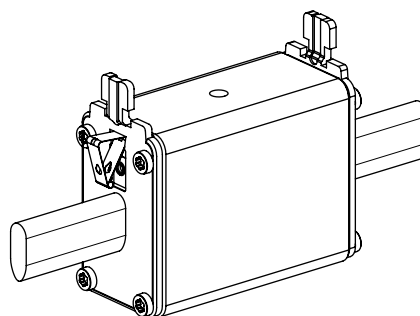
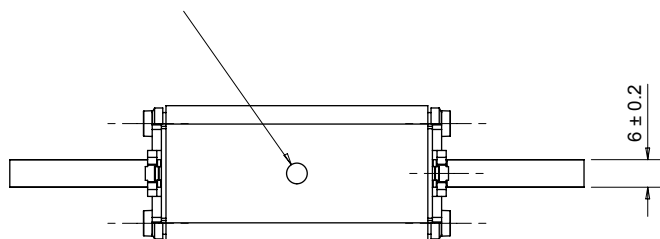

Dimensions in mm

# NH fuse-links gG 500VAC

double indicator/live gripping-lugs size 000, 00, 0, 1, 2, 3

## DIMENSIONS

### Size 1 compact with double indicator (16-100A)

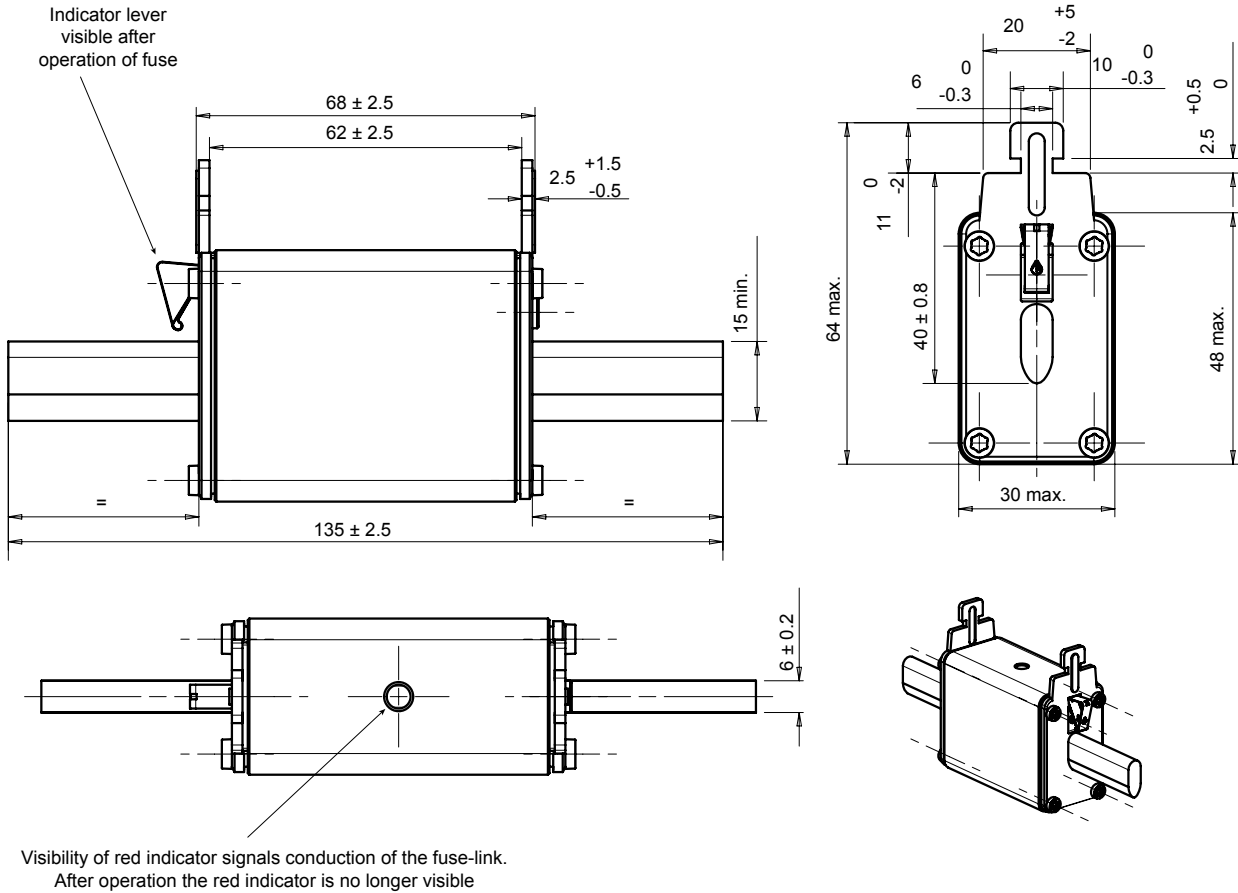

Dimensions in mm

# NH fuse-links gG 500VAC

double indicator/live gripping-lugs size 000, 00, 0, 1, 2, 3

## DIMENSIONS

### Size 1 with double indicator (125-355A)

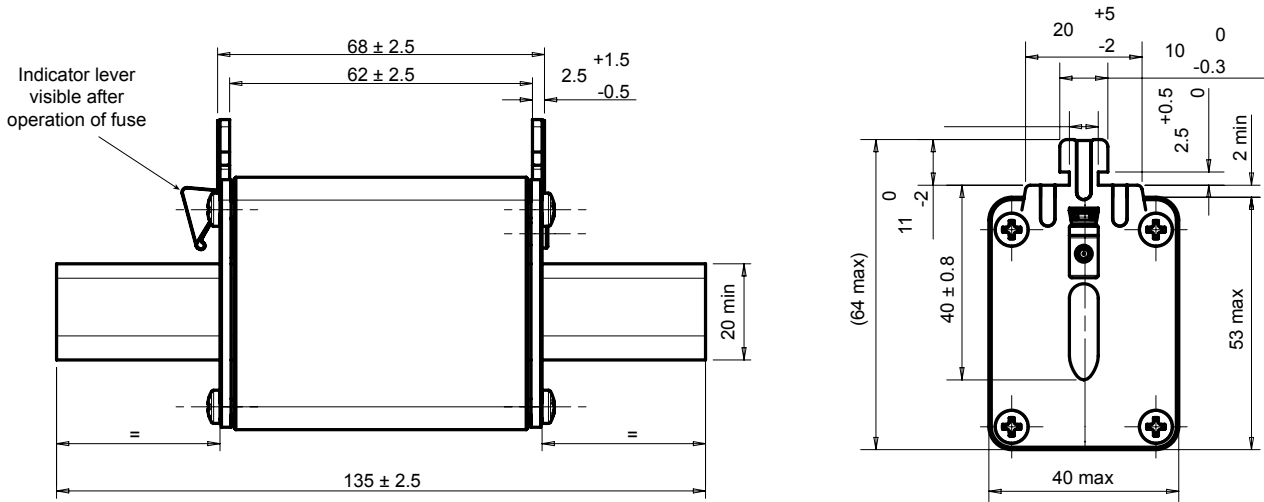

Visibility of red indicator signals conduction of the fuse-link.  
After operation the red indicator is no longer visible

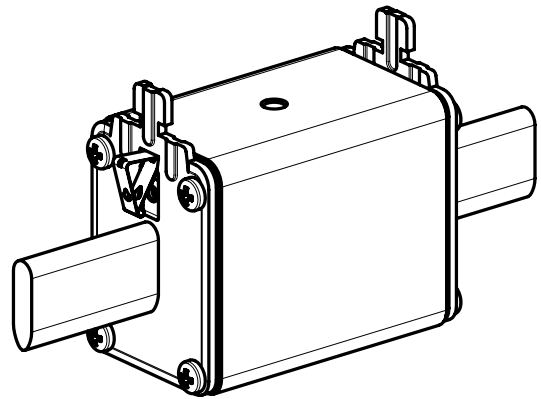
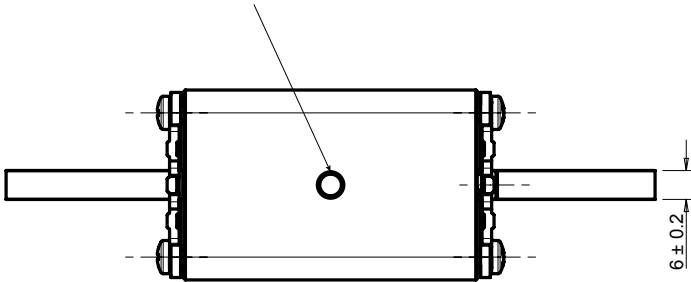

Dimensions in mm

# NH fuse-links gG 500VAC

double indicator/live gripping-lugs size 000, 00, 0, 1, 2, 3

## DIMENSIONS

### Size 2 compact with double indicator (25-250A)

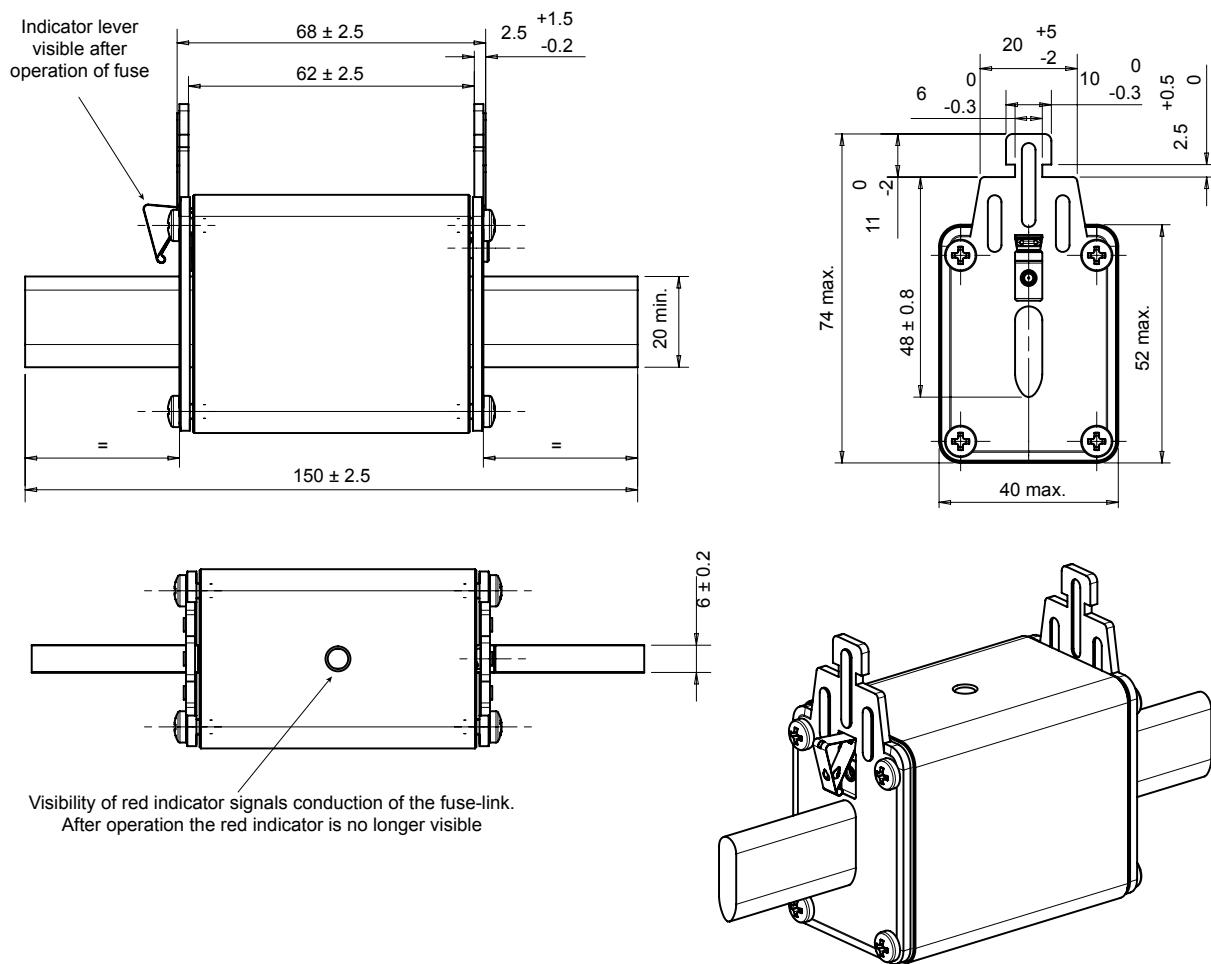

Dimensions in mm

# NH fuse-links gG 500VAC

double indicator/live gripping-lugs size 000, 00, 0, 1, 2, 3

## DIMENSIONS

### Size 2 with double indicator (300-500A)

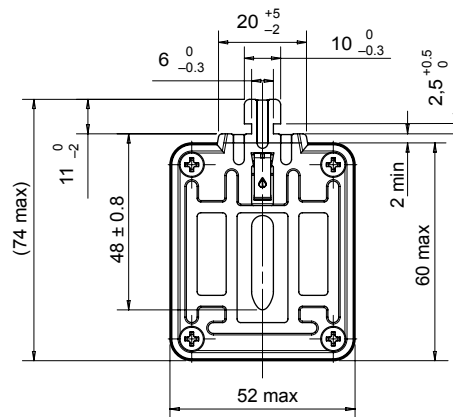
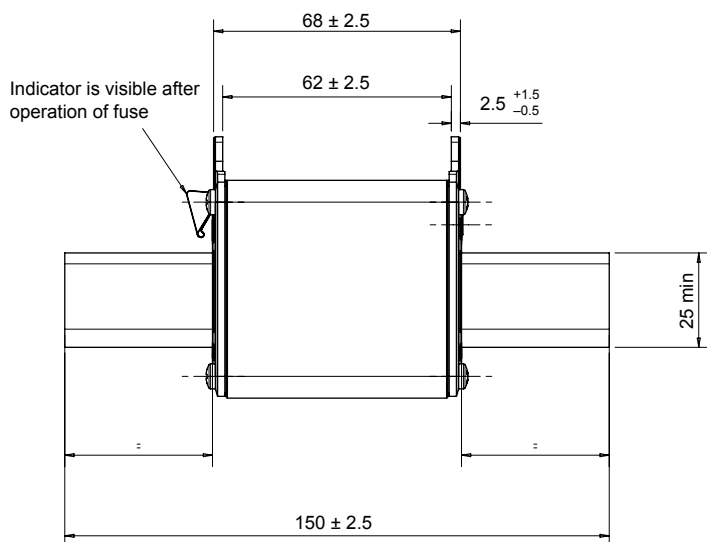

Visibility of red indicator signals conduction of the fuse-link.  
After operation the red indicator is no longer visible.

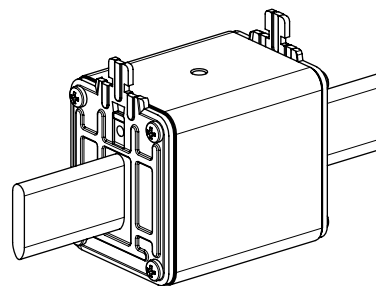
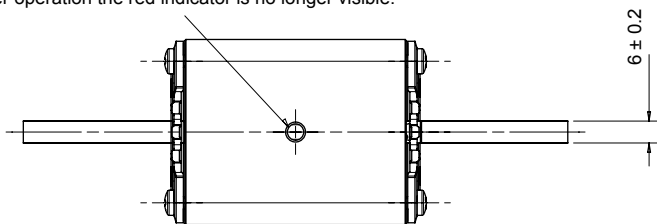

Dimensions in mm

# NH fuse-links gG 500VAC

double indicator/live gripping-lugs size 000, 00, 0, 1, 2, 3

## DIMENSIONS

### Size 3 compact with double indicator (63-400A)

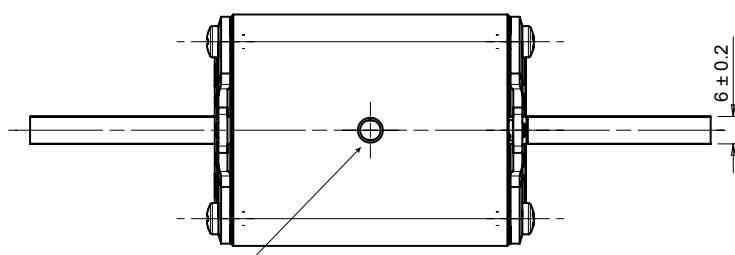
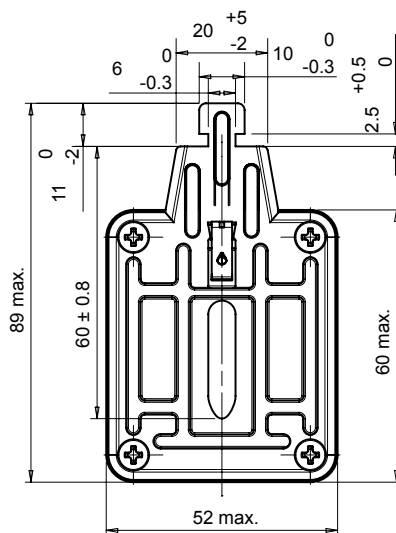
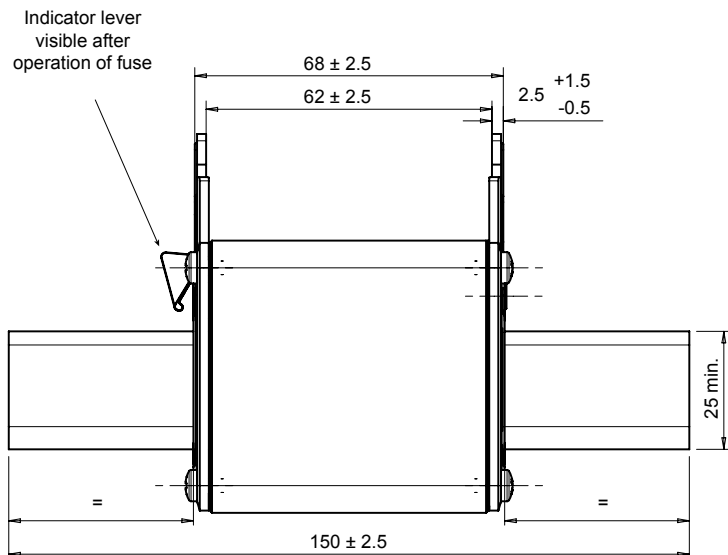

Visibility of red indicator signals conduction of the fuse-link.  
After operation the red indicator is no longer visible

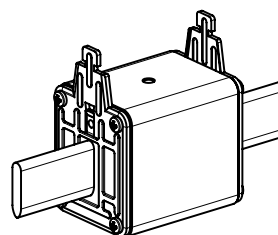

Dimensions in mm

# NH fuse-links gG 500VAC

double indicator/live gripping-lugs size 000, 00, 0, 1, 2, 3

## DIMENSIONS

### Size 3 with double indicator (425-800A)

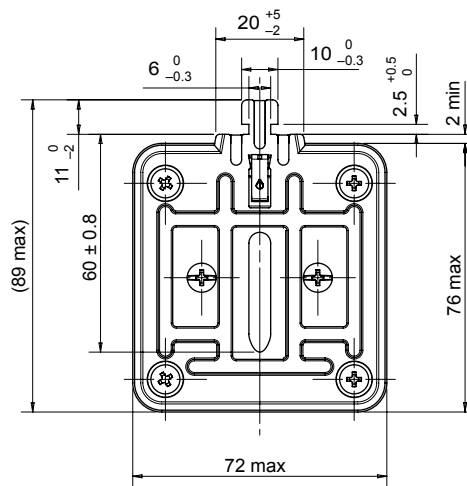
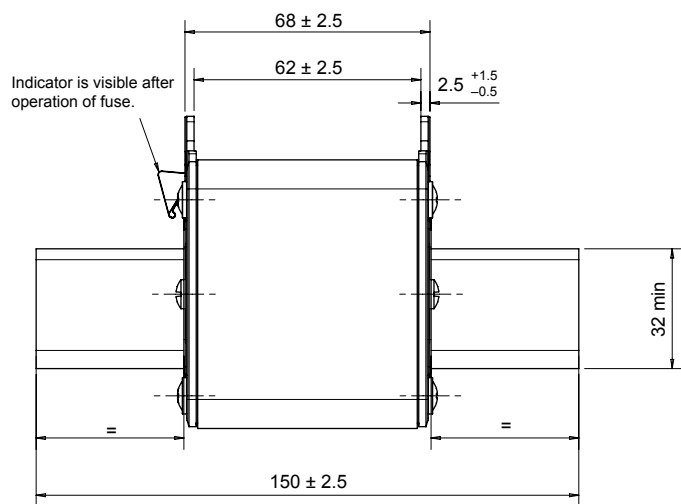

Visibility of red indicator signals conduction of the fuse-link. After operation the red indicator is no longer visible.

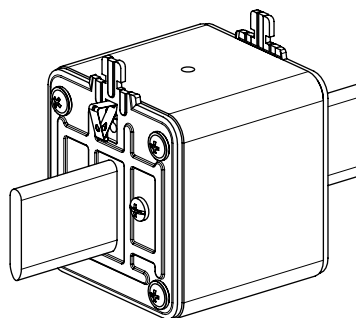
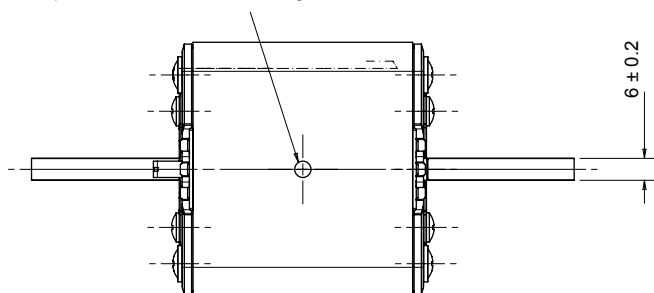

Dimensions in mm